

Cross-cultural validity of the psycho-social aspects of Facebook use (PSAFU) scale

Item Type	Journal article
Authors	Jovanovic, Tamara;Bodroža, Bojana;Orchard, Lisa;Fullwood, Chris;Kermani, Hossein;Casale, Silvia;Fioravanti, Giulia;Buljan, Ivan;Hren, Darko
Citation	Jovanović, T., Bodroža, B., Orchard, L., Fullwood, C., Kermani, H., Casale, S., Fioravanti, G., Buljan, I., & Hren, D. (2023). Cross-Cultural Validity of the Psycho-Social Aspects of Facebook Use (PSAFU) Scale. <i>Psihologija</i> , 56(1) pp. 31-62 https://doi.org/10.2298/PSI210702013J
DOI	10.2298/PSI210702013J
Publisher	Drustvo Psihologija Srbije
Journal	Psihologija
Download date	2026-06-09 04:25:14
License	https://creativecommons.org/licenses/by-sa/4.0/
Link to Item	http://hdl.handle.net/2436/624632

Cross-Cultural Validity of the Psycho-Social Aspects of Facebook Use (PSAFU) Scale*

Tamara Jovanović¹, Bojana Bodroža², Lisa Orchard³, Chris Fullwood³,
Hossein Kermani⁴, Silvia Casale⁵, Giulia Fioravanti⁵,
Ivan Buljan⁶, & Darko Hren⁷

¹Department of Geography, Tourism and Hotel Management,
Faculty of Sciences, University of Novi Sad, Serbia

²Department of Psychology, Faculty of Philosophy,
University of Novi Sad, Serbia

³Institute of Human Sciences, Faculty of Education Health and Wellbeing,
University of Wolverhampton, United Kingdom

⁴Department of Communication, University of Vienna, Austria

⁵Department of Health Sciences, Psychology and Psychiatry Unit,
University of Florence, Italy

⁶Department for Research in biomedicine and health, School of Medicine,
University of Split, Croatia

⁷Chair of Psychology, Faculty of Humanities and Social Sciences,
University of Split, Croatia

The Psycho-Social Aspects of Facebook Use (PSAFU) scale was developed by Bodroža and Jovanović (2016) to comprehensively measure psychological and social aspects of the users' Facebook (FB) experiences i.e. compensatory use of FB, self-presentation on FB, socializing, and seeking sexual partners through FB, FB addiction, and FB profile as the virtual self. The scale was previously validated on two Serbian samples. The aim of this study was to examine the validity of the PSAFU scale across multiple cultures, i.e. develop a version of the scale that would be suitable for the cross-cultural study of FB behaviors. The sample consisted of 1.632 respondents from Croatia, Italy, Iran, Serbia, and the UK. Administered questionnaires consisted of the PSAFU scale (Bodroža & Jovanović, 2016), the Big Five Inventory (BFI; John et al., 1991), the Narcissistic Personality Inventory 16 (NPI-16; Ames et al., 2006), socio-demographic, and FB use questions (e.g., time spent on FB on a daily basis, frequency of posting, and number of FB friends). After some modifications and exclusion of the Virtual Self scale, the results of multigroup confirmatory factor analysis show that the PSAFU scale is cross-culturally invariant for the cultures included in this study and suitable for use in them. The remaining dimensions of revised PSAFU scale (PSAFU-R) have statistically significant

Corresponding author: tamara.jovanovic@dgt.uns.ac.rs

* Please cite as: Jovanović, T., Bodroža, B., Orchard, L., Fullwood, C., Kermani, H., Casale, S., Fioravanti, G., Buljan, I., & Hren, D. (2023). Cross-Cultural Validity of the Psycho-Social Aspects of Facebook Use (PSAFU) Scale. *Psihologija*, 56(1), 31–62. <https://doi.org/10.2298/PSI210702013J>

relationships with measured personality traits and with indicators of FB use, although considerable cross-cultural variations were obtained.

Keywords: PSAFU scale, FB use, personality traits, cross-cultural context

Highlights:

- PSAFU-R scale could be used in the researched cultures with certain modifications.
- PSAFU-R dimensions have meaningful relations with measured personality traits.
- Indicators of FB use correlate significantly with PSAFU-R dimensions.
- Considerable cross-cultural similarities were obtained.

People are mainly motivated to create a Facebook (FB) account because of the possibility to connect and communicate with people they know offline – *social searching* and, to a lesser extent, to explore and meet new, unknown individuals – *social browsing* (Joinson, 2008; Lampe et al., 2006; Vasalou et al., 2010). More and more, the use of social networking sites (SNS) is reshaping the way people communicate and think (Kross et al., 2013). In 2016, the Psycho-Social Aspects of Facebook Use (PSAFU) scale was developed by Bodroža and Jovanović (2016) to comprehensively measure psychological and social aspects of the users' FB experiences. Having recognized that most of the available instruments at that time were focused on specific characteristics of FB, the goal of creating this scale was to construct an instrument that covers diverse aspects of Facebook use from a psychological standpoint. The authors aimed to measure both objective FB behaviors, as well as deeper psychological processes such as thoughts, feelings, and motives. Previously, this instrument was validated on a population of FB users from Serbia. The goal of this paper was to examine a wide range of FB experiences measured by the PSAFU scale and to explore the scale's properties on a more diverse sample from several countries with different cultural backgrounds: Croatia, Italy, Iran, Serbia and the UK.

Psycho-Social Aspects of Facebook Use (PSAFU) Scale

There are numerous studies about FB use and FB behavior, but most of them focus on objective indicators of FB use, such as the number of friends, frequency of posting, number of photos, time spent on FB daily, etc. However, measuring the more objective indicators of FB use leaves us blind to psychological processes and the motives behind these behaviors. Only a small number of studies have explored deeper psychological implications of FB use, such as the feelings evoked during FB interactions, motivations behind certain FB behaviors, and thoughts provoked during FB use (Bodroža & Jovanović,

2016; Ellison et al., 2007; Michikyan et al., 2014; Ross et al., 2009). The PSAFU scale is among the rare measures of FB behaviors that encompass diverse aspects of both FB behaviors and also subtle psychological processes related to FB use. The scale measures five distinct aspects of FB experiences: compensatory use of FB (compensation), self-presentation on FB (self-presentation), socializing and seeking sexual partners through FB (socializing), FB addiction (addiction), and FB profile as the virtual self (virtual self; Bodroža & Jovanović, 2016). The scale 'compensatory use of FB' measures experiences of FB users who find it easier to express themselves and communicate in a FB setting than in an offline setting. When a person carefully chooses their photos and posts in order to create certain impressions on others, they would score highly on the self-presentation scale. Those who are actively using FB as means to find new friends and sexual partners are representative of 'socializing and seeking sexual partners through FB'. The 'FB addiction' scale includes indicators of the lack of control over the time spent on FB, which in turn affects everyday life and activities. Finally, a high score on the dimension 'virtual self' is descriptive of users who perceive their FB profile as a true and reliable representation of their personality in an online setting.

The structure of the scale was first determined by Exploratory Factor Analysis (EFA) on a general population sample of FB users from Serbia, and then confirmed by Confirmatory Factor Analysis (CFA) on a student sample from Serbia. CFA also led to shortening of the scale in order to achieve a satisfactory fit. Nevertheless, the authors concluded that a longer version, even though less psychometrically sound, may have better content validity (Bodroža & Jovanović, 2016). As for psychometric characteristics, the scale showed satisfactory internal consistency with Cronbach's alphas ranging from .76 (for Virtual self) to .92 (for Compensation). The PSAFU dimensions showed stable patterns of relationships with Big Five personality traits, social anxiety and sensation-seeking. Social anxiety and conscientiousness were shown to be the most consistent determinants of all measured aspects of FB use, suggesting that FB users who are less conscientious and more socially anxious find comfort in an anonymous and controllable FB setting.

In their recent review of the scales for measuring SNS users' engagement, Sigerson and Cheng (2018) stated that the biggest concern regarding the PSAFU scale is the validity of the scale itself. Sigerson and Cheng recommended the authors show that PSAFU dimensions have meaningful relationship with measures of intensity of SNS use (e.g., time spent on SNS or frequency of posting) and measures of bridging and/or bonding social capital. The current study aims to address these concerns by examining the relationship of PSAFU dimensions with time spent online, frequency of posting, and the number of FB friends. Social capital usually refers to the resources an individual can access from their social network (Liu et al., 2016). These resources can be love and affection (bonding social capital) or information and economic benefits (bridging social capital). In this study, the number of FB friends was used as an indirect measure of social capital, which is closer to the notion of bridging

than bonding social capital. It is usually assumed that the larger the network of friends on FB one has, the more socially heterogeneous that network becomes and, consequently, the more diverse information one can reach, which is the core concept of bridging social capital (e.g., Granovetter, 1973). Sigerson and Cheng (2018) additionally suggested that objective measures of time spent online and frequency of posting would be superior to self-reported measures. In this study, due to the study design, we did not have objective data on FB use, so we had to opt for self-report measures. There are several studies that explore the relationship between objective and subjective reports of SNS use (Johannes et al., 2021; Scharkow, 2016). Johannes and colleagues (2021) have stated that there is indeed a measurement error of self-reports on SNS use, where persons tend to overestimate their SNS use. According to these authors, this tendency is not random but robust and systematic, meaning that findings that rely on self-reports can still be considered useful and informative. Finally, one should consider that FB is a worldwide phenomenon. For the questionnaire to be used in different cultures, proof of its cross-cultural validity (i.e., structural invariance) should also be provided.

Facebook Use in a Cross-Cultural Context

Research suggests that culture plays an important role in shaping SNS behavior and should therefore be taken into consideration. There are several studies that have examined the effects of national culture on SNS user behaviors (Chapman & Lahav, 2008; Jovanović et al., 2018; Karl et al., 2010; Krasnova et al., 2012; Vasalou et al., 2010) and all have led to the same conclusion – “culture is the key FB behavioral determinant” (Vasalou et al., 2010, p. 727).

FB is the most used SNS among all countries examined in this study, except Iran, where Telegram and Instagram are currently the most popular SNSs. Although we have witnessed a rise of the popularity of Instagram in the last few years, at the global level Facebook is still the most popular social network with 2.7 billion active users worldwide as compared to 1.3 billion active users of Instagram in April 2021 (Statista, 2021). The UK is currently the 12th ranking country in the world in the number of FB users, with about 38 million reported users (which is about 56% of the total UK population) in April 2021 (Statista, 2021). Based on Internet World Stat website (Internet World Stat, 2021), there were over 30 million users (about 50% of countries population) in Italy in December 2020. According to the same source, there were 1.8 million FB users (about 43%) in Croatia and 3.4 million users (about 48%) in Serbia (Internet World Stat, 2021). Iranians started joining FB from 2008 and its usage peaked during the 2009 Presidential Election and its consequent nationwide protests known as the Green Movement. Despite its blockage after the 2009 presidential elections, FB was still extensively used through a VPN and proxy servers (Eloranta et al., 2016; Khosravini & Zia, 2014) and according to Internet World Stat (Internet World Stat, 2021), there were about 40 million users in Iran in December 2021. However, Iranian sources (Boutorabi, 2012; Janati, 2014),

state that there are currently no exact estimates of the number of users, but that previously mentioned numbers are greatly exaggerated and that in 2012 the number of users was somewhere between 4 and 17 million, which is between about 5% and 22% of the total Iranian population at that time.

As an integral part of the validation process, the current study aims to explore the cross-cultural validity (i.e., structural invariance) of the PSAFU scale i.e. to come up to the scale version that will be suitable for use in cross-cultural research. In order to do this, the necessity of cross-cultural structural changes to the scale should be considered.

Personality and Facebook Use in Cross-Cultural Setting

Numerous scholars have explored the relationship between personality traits and SNS use (Amichai-Hamburger & Vinitzky, 2010; Bodroža & Jovanović, 2016; Correa et al., 2010; Orchard et al., 2014; Ross, et al., 2009; Skues et al., 2012; Wilson et al., 2010). There are two main hypotheses concerning the relationship between the use of SNS and personality characteristics. The first theory is called “compensation theory” or Poor-Gets-Richer (Kraut et al., 2002), while the other is referred to as Rich-Gets-Richer or “enhancement theory” (Kraut et al., 2002). The premise of the first theory is that those who have difficulties interacting offline (e.g., introverted, shy or socially anxious individuals) will benefit the most from using FB. On the other hand, Rich-Gets-Richer theory claims that those who are sociable and skilled in offline interactions (such as extraverts) will tend to socialize and widen their networks through SNS, because use of such services can additionally enrich their social life. Both theories have been empirically corroborated, leading to the conclusion that the relationship between personality traits and FB use depends on the motives for its use (Moore & McElroy, 2012). Nevertheless, there are no studies exploring these two theories in regards to how national culture and personality traits interact to affect SNS (FB) behavior.

Although the pattern of the relationship between Big Five personality traits and FB related behaviors in different countries can be quite diverse (Caci et al., 2014; Eftekhar et al., 2014; Fallahi & Zahra, 2015; Ivnik, 2014; Jovanović & Bodroža, 2016), some consistencies could be extracted. Most consistent results of the above-mentioned studies suggest that extraversion is almost universally a positive predictor of the number of friends and activity on FB, while higher neuroticism and lower conscientiousness predict increased time spent on FB. Openness was related to the frequency of posting in few studies, but generally agreeableness and openness vary more across studies and therefore seem to be affected more by culture.

Narcissism is also frequently researched in the context of online behaviors (Casale & Fioravanti, 2018; Mamić, 2014) Two meta-studies recently summarized these findings and showed that (grandiose) narcissism is positively related to all aspects of SNS use that were followed: time spent on SNS, number of friends and/or followers, number of photos (especially selfies), frequency of

status updates, as well as with more interaction (commenting and liking other's posts; Liu & Baumeister, 2016; McCain & Campbell, 2018). Since numerous studies show that narcissism is an important determinant of online behaviors, we have also included this personality trait in this study.

The Aims of the Study

The goal of this study was to validate the PSAFU scale in a cross-cultural context, i.e. to develop the version of the scale that would be suitable for the cross-cultural study of FB behaviors. Our aim was to examine the cross-cultural invariance of the PSAFU scale. Additionally, we tested the predictive validity of the PSAFU scale via its relationship with *intensity of FB use*, *social capital* and its discriminant validity via examining its relationship with *personality traits*. All PSAFU dimensions were expected to be positively related to time spent online with addiction achieving the strongest relationship. Frequency of posting was hypothesized to have the strongest relationship with self-presentation and socialization, since these dimensions encompass aspects of FB use directed at content creation and the active maintenance of social relations that could be achieved through posting different content. On the other hand, addiction, and compensation could be related to the frequency of posts, but to a lesser degree, since time people spend online can also be used passively for browsing other-generated content. Finally, the number of friends as an indirect measure of (bridging) social capital was expected to be primarily related to the dimension socialization, whose main content refers to establishing new online friendships.

We expected the most cross-culturally stable findings regarding extraversion being related to the indicators of online socializing. Furthermore, higher neuroticism, and lower conscientiousness were expected to be the most consistently related to the indicators of FB addiction (excessive use, inability to control time spent on FB, etc.), and compensation (which covers the other aspect of addictive behaviors). Narcissism was expected to be a relatively consistent predictor of socializing (i.e. initiating online friendships), and self-presentation on FB, since self-presentational concerns are usually achieved through status and photo posting. Also, narcissism was expected to be related to FB addiction, since this PSAFU dimension includes indicators of prolonged time spent on FB.

Method

Participants

Respondents from five countries – Croatia, Italy, Iran, Serbia and the UK, participated in this study. In every country, we aimed to gather a sample of at least 250 participants from the student population. All national subsamples were convenience samples. Gathered subsamples ranged from 251 in the UK to 429 in Italy (see Table 1). Other characteristics of the subsamples in each country are presented in Table 1. The average age of subsamples was 29.89 ($SD = 6.37$, range 18–58) in Iran, 22.39 ($SD = 3.05$, range 19–49) in Italy, 21.71 ($SD = 2.18$, range 18–30) in Croatia, 23.58 ($SD = 7.76$, range 18–58) in the UK and 21.52 ($SD = 2.39$, range 18–42) in Serbia. The structure of subsamples from Croatia, the UK,

and Serbia are very similar regarding gender (primarily female), education (majority with bachelor degree), and the place of living (around half of the sample from urban areas). The UK subsample included more students who are working part-time, while in Croatia and Serbia the majority are unemployed. The Italian subsample is better balanced regarding gender (both genders equally represented) and in place of living. Among these four countries, the structure of the subsamples is very similar regarding marital status of participants with the majority being single or in a dating relationship.

Table 1
Structure of the subsamples from five different countries

Variable	Category	Country – N (%)					Total
		Iran	Italy	Croatia	UK	Serbia	
Gender	male	182 (58.5%)	214 (49.9%)	46 (17.4%)	43 (17.1%)	109 (29.2%)	594 (36.5%)
	female	129 (41.5%)	215 (50.1%)	218 (82.6%)	208(82.9%)	264 (70.8%)	1034 (63.5%)
Education	Bachelor	0 (0%)	263 (61.4%)	131 (49.2%)	228 (90.8%)	331 (93.2%)	953 (59.3%)
	Master	266 (86.9%)	164 (38.3%)	127 (47.7%)	7 (2.8%)	24 (6.8%)	588 (36.6%)
	PhD	11 (3.6%)	1 (0.2%)	8 (3%)	16 (6.4%)	0 (0%)	36 (2.2%)
Place of living	Associate	29 (9.5%)	0 (0%)	0 (0%)	0 (0%)	0 (0%)	29 (1.8%)
	village	5 (1.6%)	195 (45.6%)	31 (11.7%)	33 (13.1%)	78 (20.9%)	342 (21%)
	up to 80.000 residents	40 (12.9%)	104 (24.3%)	68 (25.6%)	106 (42.2%)	90 (24.1%)	408 (25.1%)
	more than 80.000	265 (85.5%)	129 (30.1%)	167 (62.8%)	112 (44.6)	205 (55%)	878 (53.9%)
Employment	unemployed	97 (31.4%)	338 (79%)	241 (92%)	100 (39.8%)	333 (90.5%)	1109 (68.5%)
	full-time	121 (39.2%)	76 (17.8%)	18 (6.9%)	15 (6%)	3 (0.8%)	233 (14.4%)
	part-time	91 (29.4%)	14 (3.3%)	3 (1.1%)	136 (54.2%)	32 (8.7%)	276 (17.1%)
Marital status	married	91 (29.3%)	4 (0.9%)	2 (0.7%)	22 (8.8%)	7 (1.9%)	280 (17.2%)
	single	161 (51.8%)	185 (43.1%)	156 (58.2%)	120 (47.8%)	190 (50.9%)	764 (46.8%)
	in a relationship	46 (14.8%)	230 (53.6%)	108 (40.3%)	104 (41.4%)	172 (46.1%)	554 (33.9%)
	divorced	12 (3.9%)	0 (0%)	0 (0%)	4 (1.6%)	0 (0%)	16 (1%)
	widowed	1 (0.3%)	0 (0%)	0 (0%)	0 (0%)	0 (0%)	1 (0.1%)
	common-law union	0 (0%)	10 (2.3%)	2 (0.7%)	1 (0.4%)	4 (1.1%)	17 (1%)
Total (N)		311	429	268	251	373	1632

The Iranian subsample deserves a more detailed description, since it is slightly different from the subsamples of the other four countries. These differences could be attributed to cultural differences and specific circumstances related to FB use in this country. Since FB use in Iran was illegal at the time this research was conducted, acquiring a sample was challenging. Thus, we allowed non-students to be included in the subsample, which resulted in more full-time employed participants. Also, due to the fact that at the time of data gathering internet infrastructure in this country was mostly limited to urban areas and usually available to well-educated people, this subsample included significantly more participants from big cities and with a higher educational degree, as compared to other countries. Finally, when it comes to marital status, due to cultural specificities, the Iranian sample included more married individuals and significantly fewer individuals in a non-married relationship. The category “common-law union” was omitted from the survey because this kind of partnership is illegal in this country.

Procedure

Since this study did not raise ethical concerns, at the time when it was conducted (in the year of 2018), the ethical approval was not obligatory in any of the countries. However, it was obtained for the UK sample in line with guidance of the British Psychological Study. In Serbia, Croatia and Iran, the questionnaire was administered online while in Italy and the UK pen and paper procedure was utilized. In all the countries, socio-demographic questions were at the beginning of the questionnaire, while the order of the scales followed the order of presentation in the Instrument section. Participants from Croatia, Italy, Serbia and UK were informed about the research topic on their university courses and were invited to take part in exchange for course credit. In Iran, information about the study was shared through academic FB groups, where users were invited to fill out and share the questionnaire. All respondents were informed about the aim of the study, as well as voluntary and anonymous participation. Only individuals who gave their consent participated in the study.

Measures

Psycho-Social Aspects of Facebook Use (PSAFU; Bodroža & Jovanović, 2016) was developed for measuring a wide range of behaviors, emotions, motives, and thoughts evoked by or as a consequence of FB use. The long version of the scale consists of 43 items which measure five distinctive dimensions of FB use: compensation (13 items), self-presentation (8 items), socialization (9 items), addiction (8 items), and virtual self (5 items). Of the 43 items, 35 are presented as 5-point Likert scale items with answer categories from 1 = *it doesn't refer to me at all*, to 5 = *it completely refers to me*. The remaining 8 items are presented with a 5-point frequency Likert scale with categories from 1 = *never*, to 5 = *almost always*. In the previous study carried out on two Serbian samples (Bodroža & Jovanović, 2016), all scales had satisfactory to very good Cronbach's coefficients as measures of internal consistency (from .76 to .92). However, the long version of the scale did not reach satisfactory parameters of fit in CFA and the scale was shortened to 26 items to reach satisfactory fit indices. However, since this research was aimed at cross-cultural validation of the scale in five different countries, our starting point was the long version of the scale. The original scale was translated into different languages by the coauthors of the study. In Italy and Iran, the scale was back-translated from the English version that is available in the original article (Bodroža & Jovanović, 2016), i.e. translated from English to Italian/Persian and then back-translated into English. Since Serbian and Croatian language are very similar, the Croatian version of the scale was adapted from Serbian by changing some specific words and by adapting the grammatical structure of sentences. Item No. 40 ("I have lewd and sexual conversations on Facebook (on chat or in public or private messages).") was omitted from the analyses in all countries, because the behavior it's describing is considered inappropriate in Iran.

Big Five Inventory (BFI; John et al., 1991) is a widely used measure of Big Five personality traits (openness to experience, conscientiousness, extraversion, agreeableness, and neuroticism; 44 items), which has been translated into many languages. In this study, validated, official and/or previously used translations of the scale were used in all countries where they were available (Serbian, Italian, and English; Čolović et al., 2005; Fossati et al., 2011; John et al, 1991). In Iran and Croatia, the scale was back-translated from the English version by the national collaborator. Reliability of the BFI scales was satisfactory in most countries (Appendix A) with a few exceptions. The reliability of the Italian version of agreeableness and the UK version of openness fell somewhat below the conventional point of .70 but could still be considered acceptable. The reliability of the Iranian translation of the scales agreeableness and conscientiousness were .56 and .58, respectively. Although these values are not acceptable, we decided to use the data from these scales, but to treat the results with caution. However, in case of future use, these translations need to be refined. In all

countries, items were presented along with a 5-point Likert scale (1 = *I don't agree at all*, to 5 = *I completely agree*).

Narcissistic Personality Inventory (NPI-16). In this study, the short 16-item version of NPI was used (Ames et al., 2006) to measure narcissism. The scale consists of pairs of alternative items; one of which describes narcissistic behavior, while the other describes non-narcissistic behavior. Participants answer by choosing one of the two items which describes them best. All five translations of the scale had satisfactory internal consistency (Appendix A). All countries used the existing translation of the scale (Ames et al., 2006; Dinić & Vujić, 2019; Fossati et al., 2013; Jakšić et al., 2014), with the exception of Iran where it was back-translated from English by the national collaborator.

Socio-demographic and FB use questions. Along with the described questionnaires, additional questions regarding socio-demographic variables and a range of questions regarding FB use were administered. To measure time spent online, we asked participants "How many hours a day do you spend on Facebook?" and they responded by choosing between one of four categories: less than one hour, one to three hours, three to five hours, more than five hours. Information on the number of FB friends was gathered via an open-ended question and participants were encouraged to write down the exact number of friends at the time of completion. The question on frequency of posting was formulated as "How often do you post contents (statuses, links, photos, etc.) on your timeline?". Participants answered by choosing one of six options: more than once a day, once a day, once in two to three days, once a week, once in every few weeks, very rarely or never. As for socio-demographic variables, we gathered data on gender, age, education, place of living, employment and relationship status (see Table 1).

Data Analyses

Before starting the analyses, missing data were replaced by EM method. We first employed CFA with Maximum Likelihood estimation procedure (factor loading of the first observed variable set to 1) separately for each country to confirm the structure of the PSAFU scale. When item loadings fell below .40, the item was removed from the model in all countries. Since our goal was to reach the same model in all countries, the changes were employed in all subsamples until a satisfactory model fit was reached for all. In order to test cross-cultural stability of the PSAFU scale, we conducted a multi-group CFA. To investigate measurement invariance, we analyzed configural invariance (factor loadings and intercepts are allowed to vary between groups), metric invariance (factor loadings are equal across groups) and scalar invariance (item intercepts are equal across groups). The fit of CFA models was established through analyzing the following fit indices (Byrne, 2010): root mean square error of approximation (RMSEA), and standardized root mean square residual (SRMR), with values smaller than .08 indicating adequate fit of data to the model; Tucker Lewis Index (TLI), and Bentler's Comparative Fit Index (CFI), with values larger than .90 indicating adequate fit; and χ^2 where values that are not statistically significant indicate adequate fit of data to the tested model. To test the differences between three nested models in multi-group CFA (configural, metric, and scalar), we calculated Δ CFI, Δ RMSEA and Δ SRMR. The changes in these indicators were used because the difference in the chi-square test has been criticized as inadequate when sample size varies between groups, and when the sample size is large, both of these issues being the case in our study (Chen, 2007; Cheung & Rensvold, 2002). Changes in CFI, RMSEA and SRMR have been shown to be relatively robust and are seen as good indicators (Chen, 2007; Cheung & Rensvold, 2002). Their value should be less than .01 for all three indexes (Cheung & Rensvold, 2002).

After the structure of the final version of the PSAFU questionnaire was determined, scale scores were calculated as means of the belonging items, which gave a theoretical range of

the scales scores from 1 to 5. Descriptive statistics (mean score, standard deviation, minimum, maximum, skewness, kurtosis, and K-S test), were also calculated, as well as Cronbach's alpha (internal consistency) coefficients. All of these statistics were done separately for all five countries. Where variable distribution deviated from normal, we applied Blom's formula for normalization. Normalized variables were then used in all further analyses.

Predictive validity of the revised PSAFU scale (PSAFU-R) was explored by regression analyses in which PSAFU-R dimensions were treated as predictors of measures of the intensity of FB use (time spent on FB on daily basis and average number of posts) and of the number of FB friends. Additionally, regression analyses were used to examine the relationship between PSAFU-R dimensions and personality traits. In these analyses, personality traits were the predictors of PSAFU-R dimensions. In all the regression analyses, gender and age were added as control variables. These analyses were carried out separately on subsamples from five countries.

Results

CFA of PSAFU Scale in Five Countries

The first step in the analyses was a series of CFA of the PSAFU scale in five different countries. As mentioned in the 'Measures' section, the Iranian version of the PSAFU scale did not contain item No. 40. To be able to compare the models in all countries, we removed this item at the very beginning and did not consider it further in any country. We initially tested the structure of the longer version of the PSAFU scale (Bodroža & Jovanović, 2016) that consists of five correlated dimensions (compensation, self-presentation, socialization, addiction, and virtual self) measured by 42 items (without item No. 40). However, the model corresponding to the long version of the scale did not yield satisfactory model fit indices (Supplementary material, Table 1, <https://www.pcb-3d.com/wordpress/wp-content/uploads/Supplementary%20materials.pdf>). We then proceeded to test the short version of the PSAFU scale that, in the previous study, had good model fit indices (Bodroža & Jovanović, 2016). The short version consisted of 26 items that measure the five dimensions as described. This model had a better fit, but was also not adequate to describe the PSAFU structure in the five countries. Starting from the short version of the scale, the next step was to analyze factor loadings and modification indices. This resulted in the removal of the items 9 and 27 from the *compensation* dimension. Item 39, belonging to the FB addiction scale ("I often spend more than three hours continuously on FB"), had low loading in the Italian sample, so we discarded it from the model in all countries. Since exclusion of this item resulted in FB addiction scale having only 3 items, we retested the model with items from the longer version of this scale. One item (No. 2) showed satisfactory loading in all countries so we decided to retain it. Finally, two out of three items from the scale *Virtual Self* had low loadings in all subsamples. We retested additional items from the longer version of the scale, but they did not improve the model fit, nor did they have satisfactory factor loading. This indicated that Virtual Self

is not sufficiently empirically grounded and that it does not represent a stable construct. Therefore, we decided to completely exclude this scale. The resulting version of the PSAFU scale had 21 items within four scales and it reached a satisfactory level for most fit indices (Supplementary material, Table 1, <https://www.pcb-3d.com/wordpress/wp-content/uploads/Supplementary%20materials.pdf>). However, few modification indices indicated that additional changes would improve the model fit, especially in Iran, Italy and Croatia where some fit indices fell below the critical values. We introduced two such modifications. The first of these was the residual correlation between items No. 31 (“On Facebook I feel less pressured to be what others want me to be.”) and No. 32 (“On Facebook I feel more accepted and appreciated than I do offline.”) from the compensation scale, while the other was a residual correlation between items No. 41 (“I try to make a good impression on others by the things I post on my timeline.”) and No. 42 (“Before I post anything on Facebook, I think about how others might perceive it.”) from the self-presentation scale. In both cases, pairs of items shared additional similarity as compared to other items from the scale. In the first case it was the fear of others’ opinion, while in the second both items referred to posting contents on the FB timeline. The model with these two modifications was tested on all subsamples and it reached satisfactory levels in all countries except Iran, where it was still somewhat below the acceptable level, but better than for previous versions (Supplementary material, Table 1, <https://www.pcb-3d.com/wordpress/wp-content/uploads/Supplementary%20materials.pdf>). The structure of the final model across five countries are presented in Figures 1–5. Since the structure of the original version of the scale was slightly changed, we named this version of the scale PSAFU-R.

To check whether the content of the new version of scales sufficiently corresponds to previous versions of the scale, we calculated correlations between scores of the new, short and long versions of the scales. The results showed high overlapping of their variances (Supplementary material, Table 3, <https://www.pcb-3d.com/wordpress/wp-content/uploads/Supplementary%20materials.pdf>).

Figure 1
CFA model diagram for the data from Croatia

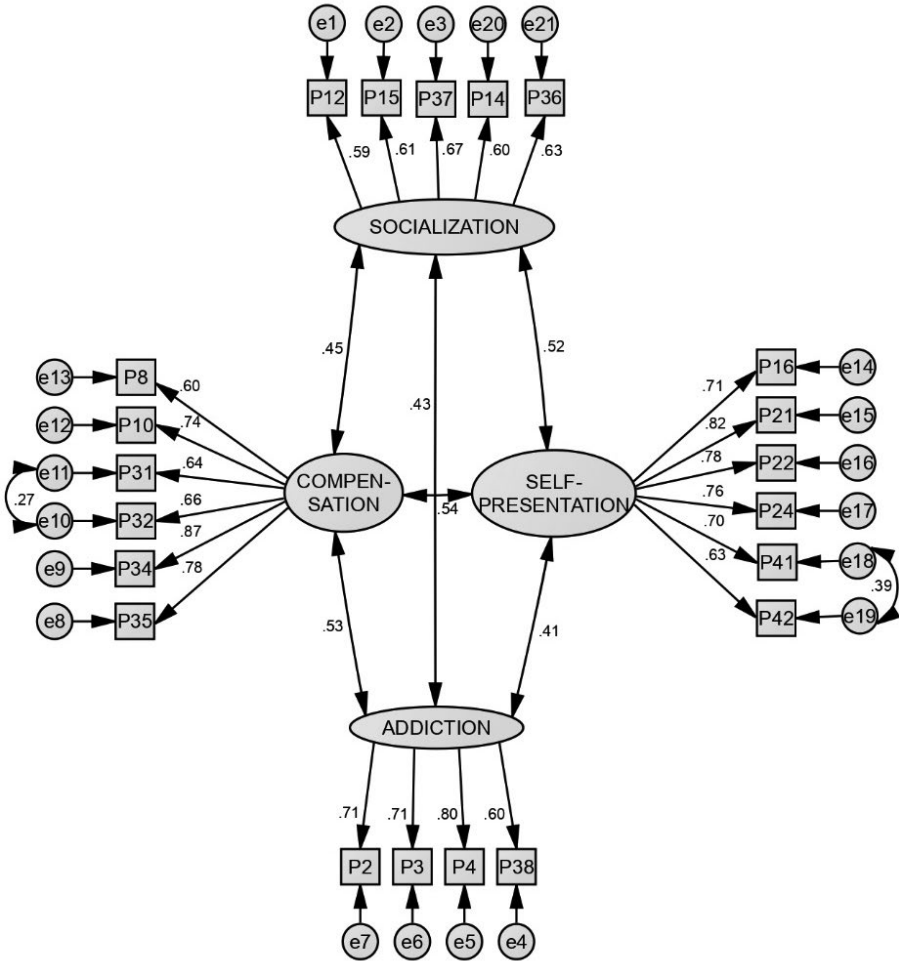

Figure 2
 CFA model diagram for the data from Iran

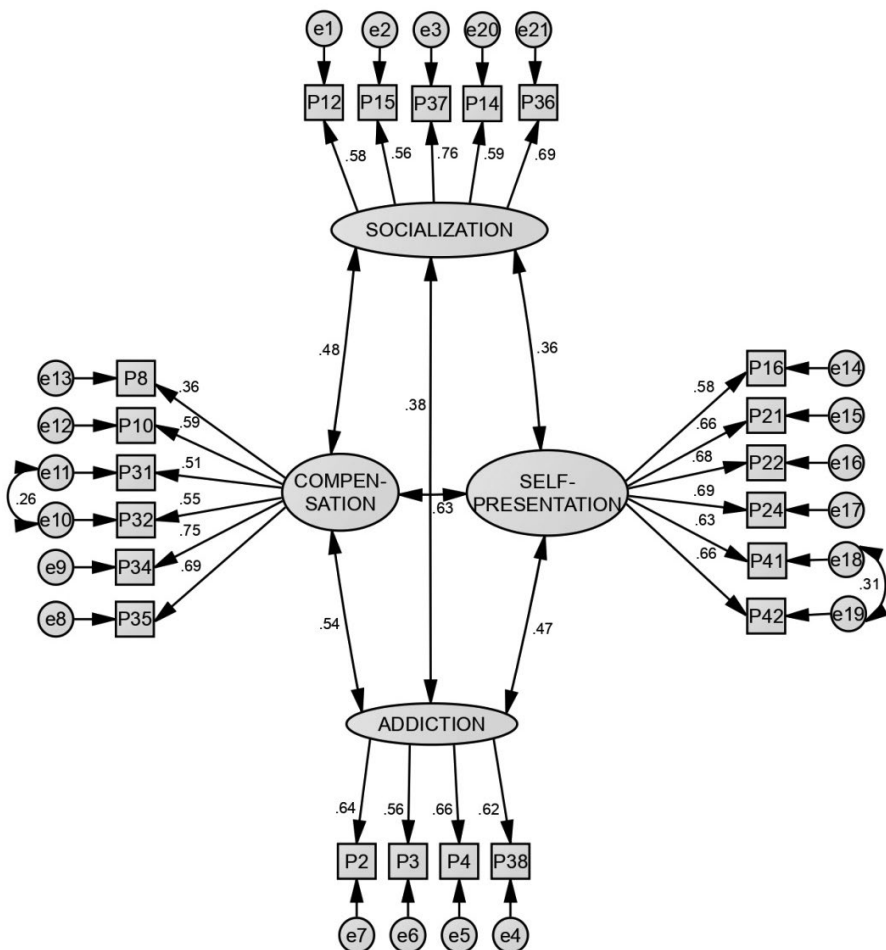

Figure 3
CFA model diagram for the data from Italy

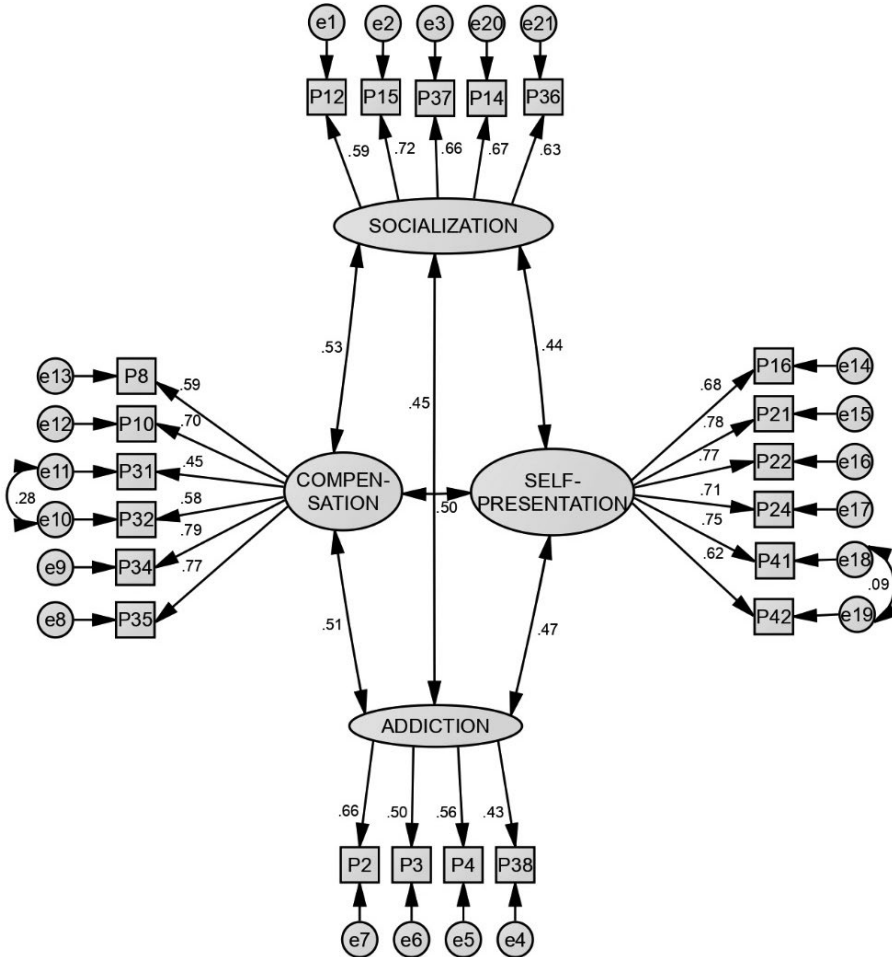

Figure 4
 CFA model diagram for the data from Serbia

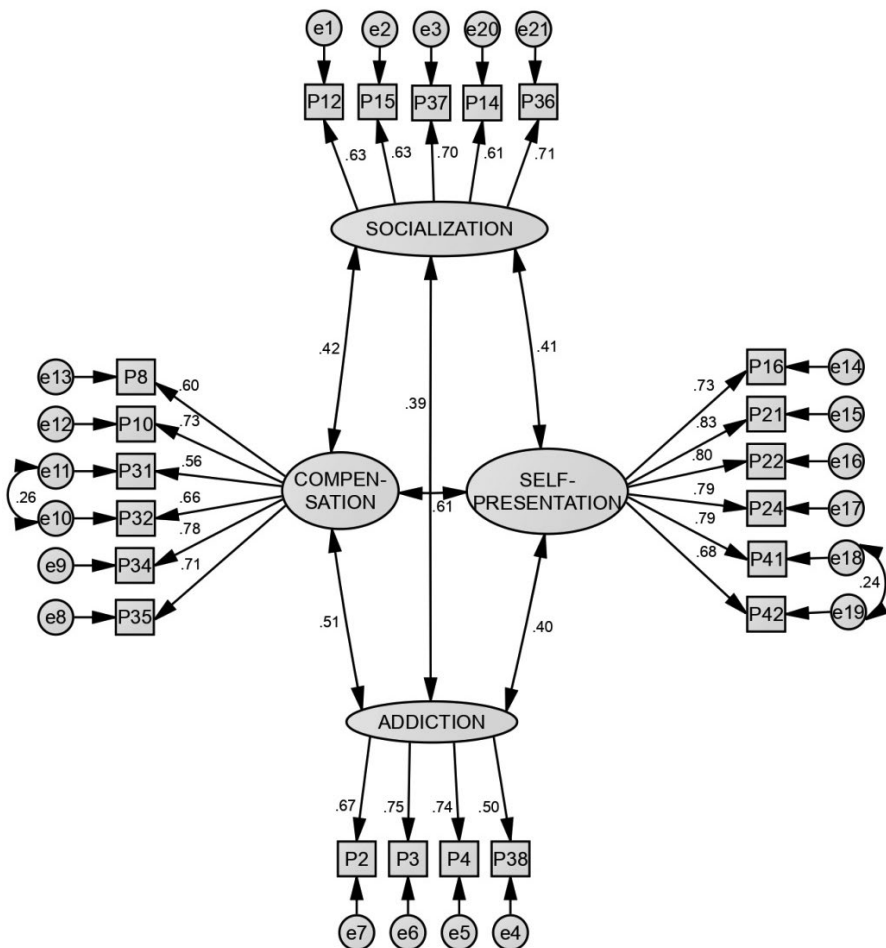
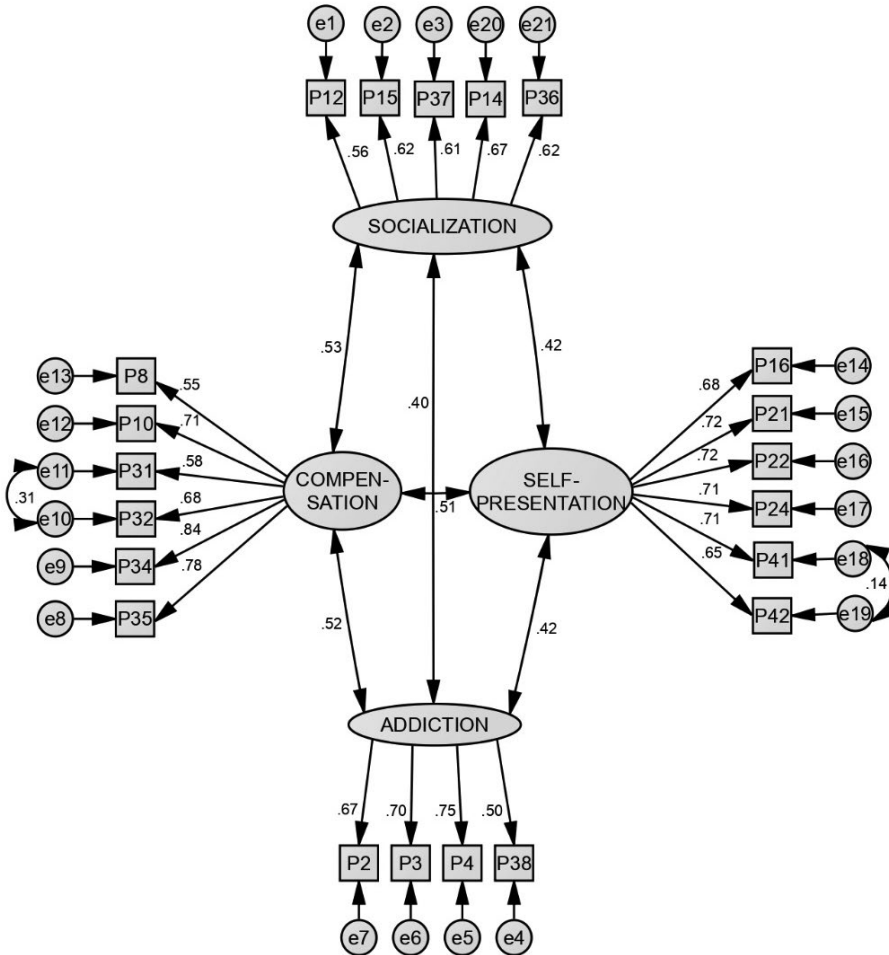

Figure 5
CFA model diagram for the data from the UK



MG-CFA of PSAFU-R Scale

The final model was achieved in CFA analyses – the model with correlated residuals was tested for multi-group invariance. The difference between the configural and metric model did not exceed the recommended criteria, but between metric and scalar did (see Table 2). This indicated that the fit had deteriorated to an extent in that the scalar model fits worse than the metric model. Muthén and Muthén (2009) indicate that it is often quite difficult to reach intercept invariance, thus we can conclude that the PSAFU-R can be viewed as *metrically* invariant. Metric invariance means that factor loadings are

the same across tested countries, but it does not allow us to compare PSAFU-R dimensions' mean scores cross-culturally. Final structure of PSAFU-R scale in five countries is presented on Figures 1–5.

Table 2
Goodness of fit indices for final model

Model	Invariance	χ^2	<i>p</i>	<i>df</i>	TLI	CFI	RMSEA (95%CI)	SRMR	Δ CFI	Δ RMSEA	Δ SRMR
new version with correlated errors	Configural	1905.717	.000	905	.909	.912	.026 (.024-.028)	.069			
new version with correlated errors	Metric	2226.644	.000	973	.895	.902	.028 (.027-.030)	.083	.010	.002	.002
new version with correlated errors	Scalar	4100.192	.000	1057	.764	.763	.042 (.041-.043)	.090	.139	.014	.012

Descriptive Statistics

Descriptive statistics for the PSAFU-R and personality variables are shown separately for the five countries participating in the study. The descriptive data for all continuous variables are shown in Appendix A, while the descriptives for the time spent on FB on a daily basis and frequency of posting are shown in Appendix B. Since analyses showed that the distribution of all continuous variables significantly differed from normal, we normalized them and such scores were used in all further analyses.

Predictive and Discriminant Validity of PSAFU-R Dimensions Across Countries

To explore predictive validity of PSAFU-R dimensions, we regressed them on to the measures of the intensity of FB use and social capital, i.e. to the time spent on FB on a daily basis, the frequency of posts, and the number of FB friends. The most consistent predictor of both the time spent daily on FB and the frequency of posting across five countries was addiction. Socialization also predicted frequency of posting in Italy, Croatia, and Serbia. When it comes to the number of FB friends, none of the PSAFU-R dimensions predicted the criterion in all countries. Compensation was related to the number of FB friends in Italy, Croatia, and the UK, and socialization was related to the same criterion in Iran, Italy, and Serbia. Other predictors that contributed to the three criterion variables in individual countries could be seen in the Table 3.

Table 3
Regression analyses predicting time spent of FB on daily basis, frequency of posting and number of FB friends based on the PSAFU dimensions across five countries

	Country														
	Iran			Italy			Croatia			UK			Serbia		
	β	<i>t</i>	<i>p</i>	β	<i>t</i>	<i>p</i>	β	<i>t</i>	<i>p</i>	β	<i>t</i>	<i>p</i>	β	<i>t</i>	<i>p</i>
Dependent variable: Time spent on FB on daily basis															
Gender	.01	.25	.81	.10	2.22	.03	-.02	-.33	.74	-.01	-.26	.80	.04	.76	.45
Age	.13	2.53	.01	-.09	-2.00	.05	.01	.22	.83	.12	2.08	.04	.04	.85	.40
Compensation	-.01	-.10	.91	.09	1.83	.07	.00	-.02	.99	.07	.94	.35	-.01	-1.16	.87
Self-Presentation	-.03	-.48	.63	.03	.61	.55	-.06	-.94	.37	.04	.63	.53	-.13	-2.26	.02
Socialization	.24	4.27	.00	.07	1.40	.16	.10	1.55	.12	.06	.99	.32	.22	4.13	.00
Addiction	.37	6.44	.00	.42	8.82	.00	.53	8.51	.00	.49	7.91	.00	.45	8.47	.00
R	.51			.53			.55			.56			.51		
$F(df_{bg}, df_{wg})$	16.62(6, 297)			26.78(6, 413)			18.08(6, 262)			17.85(6, 244)			20.99(6, 370)		
<i>p</i>	< .001			< .001			< .001			< .001			< .001		
Dependent variable: Frequency of posting															
Gender	.04	.61	.54	.10	2.09	.04	.08	1.40	.16	-.01	-.10	.93	.09	1.70	.09
Age	.08	1.43	.15	.06	1.26	.21	.22	3.80	.00	.19	3.15	.00	.00	.07	.95
Compensation	.07	.10	.32	-.02	-.33	.74	-.04	-.51	.61	-.01	-.13	.90	.00	-.04	.97
Self-Presentation	.05	.79	.43	.07	1.39	.17	-.06	-.85	.40	.05	.66	.51	-.09	-1.49	.14
Socialization	.08	1.29	.20	.24	4.62	.00	.17	2.50	.01	.13	1.89	.06	.30	5.39	.00
Addiction	.23	3.68	.00	.25	4.84	.00	.22	3.17	.00	.34	4.97	.00	.21	3.74	.00
R	.34			.42			.35			.43			.38		
$F(df_{bg}, df_{wg})$	6.33(6, 297)			14.83(6, 412)			5.95(6, 262)			8.82(6, 243)			10.47(6, 370)		
<i>p</i>	< .001			< .001			< .001			< .001			< .001		
Dependent variable: Number of FB friends															
Gender	-.21	-3.64	.00	.06	1.31	.19	.05	.80	.43	.03	.53	.60	-.04	-.66	.51
Age	.03	.59	.56	-.24	-5.15	.00	.08	1.33	.18	-.19	-2.94	.00	-.08	-1.60	.11
Compensation	-.06	-.79	.43	-.19	-3.48	.00	-.14	-1.84	.07	-.25	-3.12	.00	-.04	-.52	.60
Self-Presentation	.15	2.33	.02	.01	.12	.90	-.04	-.59	.56	.13	1.76	.08	.03	.43	.67
Socialization	.13	2.06	.04	.19	3.59	.00	.10	1.33	.18	.11	1.54	.13	.14	2.30	.02
Addiction	.12	1.92	.06	.22	4.19	.00	.22	3.08	.00	.07	1.02	.31	.11	1.73	.08
R	.36			.39			.24			.29			.23		
$F(df_{bg}, df_{wg})$	7.10 (6, 298)			12.42 (6, 412)			2.52 (6, 254)			3.66 (6, 243)			3.24 (6, 370)		
<i>p</i>	< .001			< .001			.022			.002			.004		

Note. Gender was coded as 0 = male, 1 = female.

The discriminant validity was examined by analyzing the patterns of relationships between PSAFU-R scale dimensions, on the one hand, and Big Five personality traits and narcissism, on the other while controlling for gender and age. The results are presented in Table 4 – by country. They revealed that compensation was uniquely related to introversion (in all countries) and higher neuroticism (in Iran, UK, and Serbia). Self-presentation was predicted by higher neuroticism and narcissism (in all countries except Croatia). Similarly, the most consistent predictor of socialization was narcissism (in all countries except

Croatia) and neuroticism (in Croatia, UK and Serbia). Socializing on FB was also more pronounced among males (in all countries except UK) and younger people in Italy, UK, and Serbia, but among older people in Iran. Finally, as with self-presentation and socialization, addiction was predicted by narcissism (in all countries except Croatia) and neuroticism (in Croatia, UK, and Serbia). Addiction was also more pronounced among men (in all countries except UK) and younger people (in Italy, UK, and Serbia). Other predictors of PSAFU-R dimensions which were less consistent across countries can be seen in Table 4.

Table 4
Regression analyses predicting PSAFU dimensions based on the personality traits across five countries

Predictor	Country														
	Iran			Italy			Croatia			UK			Serbia		
	β	<i>t</i>	<i>p</i>	β	<i>t</i>	<i>p</i>	β	<i>t</i>	<i>p</i>	β	<i>t</i>	<i>p</i>	β	<i>t</i>	<i>p</i>
Dependent variable: Compensation															
Gender	-.22	-3.88	.00	-.01	-.11	.92	-.08	-1.29	.20	-.11	-1.81	.07	.03	.54	.59
Age	.01	.23	.82	-.02	-.31	.76	-.08	-1.38	.17	-.12	-1.78	.08	-.15	-3.15	.00
Extraversion	-.13	-1.99	.05	-.33	-6.11	.00	-.25	-3.35	.00	-.25	-3.60	.00	-.40	-7.34	.00
Agreeableness	.05	.81	.42	.00	.09	.93	-.05	-.66	.51	.12	1.86	.06	.00	.03	.98
Conscientiousness	-.06	-.88	.38	-.04	-.81	.42	-.02	-.27	.79	-.14	-2.09	.04	-.15	-3.04	.00
Neuroticism	.12	1.99	.05	.08	1.45	.15	.04	.59	.55	.15	2.33	.02	.12	2.34	.02
Openness	.04	.69	.49	.03	.58	.56	-.08	-1.13	.26	-.04	-.59	.56	.06	1.12	.26
Narcissism	.08	1.35	.18	.17	3.01	.00	-.03	-.43	.67	.12	1.72	.09	.15	2.80	.01
<i>R</i>	.31			.33			.36			.42			.49		
<i>F</i> (<i>df</i> _{bg} , <i>df</i> _{wg})	3.86(8, 298)			6.27(8, 415)			4.64(8, 261)			6.48(8, 249)			14.27(8, 370)		
<i>p</i>	< .001			< .001			< .001			< .001			< .001		
Dependent variable: Self-presentation															
Gender	-.13	-2.39	.02	.06	1.15	.25	-.07	-1.10	.27	-.08	-1.25	.21	.09	1.75	.08
Age	-.07	-1.24	.21	.01	.12	.90	-.08	-1.24	.22	-.11	-1.67	.10	-.07	-1.46	.14
Extraversion	-.08	-1.34	.18	-.14	-2.49	.01	-.04	-.57	.57	-.07	-.96	.34	-.19	-3.18	.00
Agreeableness	.10	1.58	.12	.05	.98	.33	.08	1.00	.32	.22	3.32	.00	.04	.75	.46
Conscientiousness	-.05	-.79	.43	.04	.88	.38	-.16	-2.34	.02	-.07	-.99	.32	-.06	-1.10	.27
Neuroticism	.21	3.58	.00	.13	2.36	.02	.10	1.40	.16	.25	3.63	.00	.26	4.72	.00
Openness	.11	1.77	.08	.03	.67	.50	-.01	-.11	.91	-.01	-.12	.91	.09	1.76	.08
Narcissism	.23	3.94	.00	.28	4.92	.00	.07	.91	.36	.24	3.44	.00	.20	3.49	.00
<i>R</i>	.40			.28			.22			.36			.38		
<i>F</i> (<i>df</i> _{bg} , <i>df</i> _{wg})	6.88(8, 298)			4.23(8, 415)			1.64(8, 261)			4.61(8, 249)			7.67(8, 370)		
<i>p</i>	< .001			< .001			.114			< .001			< .001		
Dependent variable: Socialization															
Gender	-.20	-3.62	.00	-.15	-2.84	.00	-.22	-3.55	.00	-.06	-1.00	.32	-.27	-5.23	.00
Age	.11	2.04	.04	-.10	-2.14	.03	-.06	-1.08	.28	-.13	-1.94	.05	-.10	-2.00	.05
Extraversion	.10	1.57	.12	-.02	-.29	.77	.16	2.18	.03	-.03	-.42	.67	.13	2.20	.03
Agreeableness	-.10	-1.54	.12	.00	.10	.92	.03	.35	.72	.01	.14	.89	.06	1.02	.31
Conscientiousness	-.01	-.21	.83	-.01	-.11	.91	-.19	-3.01	.00	-.05	-.67	.50	-.13	-2.58	.01
Neuroticism	.02	.33	.74	.03	.51	.61	.17	2.41	.02	.23	3.29	.00	.19	3.60	.00

Predictor	Country														
	Iran			Italy			Croatia			UK			Serbia		
	β	<i>t</i>	<i>p</i>	β	<i>t</i>	<i>p</i>	β	<i>t</i>	<i>p</i>	β	<i>t</i>	<i>p</i>	β	<i>t</i>	<i>p</i>
Openness	.15	2.36	.02	.08	1.58	.11	-.06	-.86	.39	-.02	-.27	.78	.06	1.22	.22
Narcissism	.17	2.74	.01	.18	3.17	.00	.14	1.82	.07	.15	2.16	.03	.16	2.76	.01
<i>R</i>	.37			.29			.36			.32			.41		
$F(df_{bg}, df_{wg})$	5.57(8, 298)			4.83(8, 415)			4.76(8, 261)			3.53(8, 249)			9.09(8, 370)		
<i>p</i>	< .001			< .001			< .001			< .001			< .001		
Dependent variable: Addiction															
Gender	-.20	-3.62	.00	-.15	-2.84	.00	-.22	-3.55	.00	-.06	-1.00	.32	-.27	-5.23	.00
Age	.11	2.04	.04	-.10	-2.14	.03	-.06	-1.08	.28	-.13	-1.94	.05	-.10	-2.00	.05
Extraversion	.10	1.57	.12	-.02	-.29	.77	.16	2.18	.03	-.03	-.42	.67	.13	2.20	.03
Agreeableness	-.10	-1.54	.12	.00	.10	.92	.03	.35	.72	.01	.14	.89	.06	1.02	.31
Conscientiousness	-.01	-.21	.83	-.01	-.11	.91	-.19	-3.01	.00	-.05	-.67	.50	-.13	-2.58	.01
Neuroticism	.02	.33	.74	.03	.51	.61	.17	2.41	.02	.23	3.29	.00	.19	3.60	.00
Openness	.15	2.36	.02	.08	1.58	.11	-.06	-.86	.39	-.02	-.27	.78	.06	1.22	.22
Narcissism	.17	2.74	.01	.18	3.17	.00	.14	1.82	.07	.15	2.16	.03	.16	2.76	.01
<i>R</i>	.37			.29			.36			.32			.41		
$F(df_{bg}, df_{wg})$	5.57(8, 298)			4.83(8, 415)			4.76(8, 261)			3.53(8, 249)			9.09(8, 370)		
<i>p</i>	< .001			< .001			< .001			< .001			< .001		

Note. Gender was coded as 0 = male, 1 = female.

Discussion

The main focus of this study was to examine the applicability of the Psycho-Social Aspects of FB Use (PSAFU) scale in a wider cross-cultural context, to offer a version of the scale that is cross-culturally invariant and to analyze and describe the cross-cultural similarities of FB experiences and their correlates. Specifically, PSAFU was explored on samples from Croatia, Iran, Italy, Serbia, and the UK. The aims were to examine the stability of the scale's latent structure in different cultural contexts and then to examine relations of PSAFU dimensions with relevant constructs – the indicators of FB use and personality characteristics.

The results show that the PSAFU scale is invariant for the examined five cultures and suitable for use in them, but with certain modifications to the scale's structure (PSAFU-R). None of the previous versions fitted the data completely. The analyses indicated that the dimension virtual self is not sufficiently empirically grounded and, due to the low item loadings in all studied countries, it was not possible to create an acceptable version of this scale. Therefore, for the purpose of cross-cultural comparison, the scale was completely excluded. The elimination of the whole scale suggests that FB experiences encompassed by this dimension are probably unstable and inconsistent in the examined cultures. One possible reason for this could be the fluidity of the FB phenomenon itself, which leads to changes in users' behaviors encompassed by this dimension. As a consequence of that, these behaviors seem to no longer vary together and

constitute a mutual latent phenomenon. It should be noted that this PSAFU dimension had the least favorable psychometric characteristics even in the first two validation studies (see Bodroža & Jovanović, 2016) and that items encompassed in it were somewhat heterogeneous in their content.

Results indicate that the final version of the scale consisting of the 21 items distributed over the four remaining dimensions (i.e., compensation, self-presentation, socialization, and addiction) is metrically invariant. Metric variance is the least requisite for the use of scale in cross-cultural studies, as it indicates that the structure of the instrument is the same in different cultures, which enables its use for valid cross-cultural comparisons of variances and correlations. However, scalar invariance was not obtained, suggesting that intercepts of the scales could vary in different countries and thus, the scale should not be used for mean-level cross-cultural comparisons of FB users' behaviors. The lack of scalar invariance could be attributed to few possible causes. First, it might be due to the differences in the samples from the different countries, primarily with regard to gender and age structure, which varied significantly. Creating a uniform sample is an endeavor for the future studies of cross-cultural invariance of PSAFU-R. A second explanation could lie in different cultural contexts, especially in Iran, where the pattern of FB use was generally different and the use of this SNS was illegal. For example, in Iran, posting contents of FB was the rarest behavior and users had the least friends. A third possible explanation of the lack of scalar invariance lies in the process of translation. A more rigorous procedure that includes several professional translators might have resulted in different outcomes for the scale. Nevertheless, internal consistency of the final version of the scales was satisfactory in all five countries and correlations of these dimensions with the original long and short versions of the scale confirmed their content validity.

In order to determine the predictive validity of the PSAFU-R scale, we explored its relations with three self-reported measures of FB use: time spent online on a daily basis, frequency of posting and the number of FB friends. Results indicate that all PSAFU-R dimensions have meaningful relationships with all of these measures.

As was hypothesized, *time spent on FB on a daily basis* achieved the highest and most cross-culturally consistent relationship with the addiction dimension in all countries. This finding is in accordance with one of the main features of FB addiction pertaining to the prolonged time spent on this SNS. We further hypothesized the relationship between *frequency of posting*, as a measure of the intensity of FB use, with socialization and self-presentation. Results partially supported this expectation. Socialization does correlate with frequency of posting in three out of five countries included in this study. However, the hypothesis regarding the dimension self-presentation was not substantiated. Interestingly, frequency of posting achieved the highest correlations with addiction in all countries, suggesting that addictive FB users might use this SNS in active rather than passive way (see Gerson et al., 2017). The results show that frequent posting on FB is mainly indicative of individuals who have trouble

controlling their FB use and who use it for the purposes of establishing and maintaining social connections. Also, we hypothesized that the *number of FB friends* would primarily be related to the PSAFU-R dimension socialization. This was confirmed in Iran, Italy, and Serbia, but not in Croatia and the UK. Although this result might seem counterintuitive, it seems that the socialization dimension does not necessarily have to be correlated with a large number of friends. People can add a large number of friends on FB, but have zero or seldom communication with them, which is the core facet of the dimension. In addition, people can have a small number of FB friends with whom they communicate intensely. Finally, the correlation of number of friends with lower scores on compensation and higher scores on FB addiction was observed in Italy and Croatia. It may be that this pattern of results represents a suppression effect, as revealed when compared to Pearson correlations reported in Supplementary material, Table 4 (<https://www.pcb-3d.com/wordpress/wp-content/uploads/Supplementary%20materials.pdf>). Therefore, caution is needed when interpreting these findings.

Our final step was to examine discriminant validity i.e. which psycho-social aspects of FB use are universally related to personality characteristics and which of these relations could be interpreted in terms of cross-cultural similarities vs. specificities. In line with the compensation theory and with our hypothesis, compensation is most consistently related to introversion and neuroticism in all countries. Therefore, the typical compensating user profile is a less sociable individual who has fewer social contacts and high emotional reactivity, which greatly confirms the profile described by Bodroža & Jovanović (2016).

Self-presentation, socialization and FB addiction revealed a similar pattern of relationships with personality traits. Higher narcissism and higher neuroticism seem to motivate self-presentational concerns and a need for establishing social contacts in a FB setting, as well as prolonged and addictive FB use. These results are consistent with the findings of several previous studies (Mehdizadeh, 2010; Michikyan et al., 2014; Ong et al., 2011; Seidman, 2013). Since (grandiose) narcissism and neuroticism are not usually associated (e.g., Miller et al, 2011), it is more probable that these results refer to two different FB personality profiles. Narcissistic personality profile suggests that these individuals use online settings to acquire more social interactions i.e. they are getting socially richer from using the Internet (Rich-Gets-Richer theory; Kraut et al., 2002). However, it seems that getting “rich” doesn’t necessarily have to be interpreted in terms of social contacts, but can also be in terms of general self-image enhancement. Making new FB friends means a greater number of connections and these connections may empower a person and make them feel worthier, especially when effective self-presentation tactics are enacted. On the other hand, individuals characterized by high neuroticism seem to use FB friendships and opportunities for impression management to compensate personal insecurities, which is in line with Poor-Gets-Richer i.e. compensation theory (Kraut et al., 2002). Along the same lines, previous research by Bodroža & Jovanović (2016) showed that social anxiety was the strongest predictor of this aspect of FB use. Taken together, these findings indicate that emotional sensitivity, especially related to social relations, is motivating people to seek affirmation online. For these individuals, FB use

can also be a way to manage one's emotions in situations of stress, which can be the cause of compulsive and addictive FB behaviors.

From a theoretical point of view, the results of this study, in general, indicate that the Rich-Gets-Richer and Poor-Gets-Richer (i.e., compensation) are not mutually exclusive, but complementary theories. It appears that both an individual's motives for FB use and their specific cultural context may play a role in this.

Finally, a few gender and age specific FB use patterns emerged in this study. Younger FB users, who represent the most engaged FB users, are more prone to socializing through FB and FB addiction. A similar pattern was obtained for males. Although a number of studies that have shown that women use SNS for maintaining social connections might seem to contradict our findings (e.g., Muscanell & Guadagno, 2012), it should not be overlooked that the PSAFU-R dimension of socialization encompasses not only establishing new friendships, but also active seeking of sexual relationships through FB. This might be the reason for these seemingly inconsistent findings. However, the results pertaining to males practicing more addictive FB behaviors should be interpreted with caution. Namely, simple gender comparisons (see Supplementary material, Table 6, <https://www.pcb-3d.com/wordpress/wp-content/uploads/Supplementary%20materials.pdf>) revealed that gender differences in FB addiction in most countries did not exist and where they did, their direction was not consistent.

There are a number of limitations of this study that need to be addressed. In order to control the sample variability, but also due to its availability, we opted for student samples in all countries. Thus, conclusions from this study are not entirely generalizable to the wider population. Also, although in Iran students were invited to participate in the study, this sample is somewhat different in structure and characteristics. Data obtained on the Iranian sample showed a weaker fit to the scale structure, but it is hard to conclude whether this was the consequence of the specificity of the sample, of cultural factors or of something else. Further studies should investigate these concerns. The distribution of gender was also not controlled, which resulted in a predominantly female samples in Croatia, Serbia, and the UK. In our study, we relied on the self-reported data on features of FB use, which were shown to be only moderately valid in comparison to objective data from client log files (Johannes et al., 2021; Scharkow, 2016). Therefore, whenever it is possible, objective data should be used. In the future, it would be interesting to examine the psycho-social aspects of FB use on samples from a more general and more representative population. As previously mentioned, one possible reason for the lack of scalar invariance of PSAFU-R scale might be due to inadequate rigor around translations of the scale. It is possible that some items might have been interpreted differently in different cultural contexts. Thus, translations used in this study should be additionally analyzed and, if needed, refined.

To conclude, this study shows that the PSAFU-R scale can be used in Croatian, Italian, Iranian, Serbian, and the UK cultures for studying cross-cultural similarities and differences in Facebook use. Authors working in this field of study could take this instrument into consideration when designing their studies.

References

- Ames, D. R., Rose, P., & Anderson, C. P. (2006). The NPI-16 as a short measure of narcissism. *Journal of Research in Personality*, 40(4), 440-450. <https://doi.org/10.1016/j.jrp.2005.03.002>
- Amichai-Hamburger, Y., & Vinitzky, G. (2010). Social network use and personality. *Computers in Human Behavior*, 26(6), 1289–1295. <https://doi.org/10.1016/j.chb.2010.03.018>
- Bodroža, B., & Jovanović, T. (2016). Validation of the new scale for measuring behaviors of Facebook users: Psycho-Social Aspects of Facebook Use (PSAFU). *Computers in Human Behavior*, 54, 425–435. <https://doi.org/10.1016/j.chb.2015.07.032>
- Boutorabi, M. (2012, April 10). *Does Facebook have 17 million members in Iran?* Asriran website. <https://www.asriran.com/fa/news/183862/17-%D9%85%DB%8C%D9%84%DB%8C%D9%88%D9%86-%D8%A7%DB%8C%D8%B1%D8%A7%D9%86%DB%8C-%D8%B9%D8%B6%D9%88-%D9%81%DB%8C%D8%B3%E2%80%8C%D8%A8%D9%88%D9%83-%D9%87%D8%B3%D8%AA%D9%86%D8%AF>
- Byrne, B. M. (2010). *Structural equation modeling with AMOS: Basic concepts, applications, and programming* (2nd ed.). Erlbaum.
- Caci, B., Cardaci, M., Tabacchi, M. E., & Scrima, F. (2014). Personality Variables as Predictors of Facebook Usage. *Psychological Reports*, 114(2), 528–539. <https://doi.org/10.2466/21.09.PR0.114k23w6>
- Casale, S., & Fioravanti, G. (2018). Why narcissists are at risk for developing Facebook addiction: The need to be admired and the need to belong. *Addictive Behaviors*, 76, 312–318. <https://doi.org/10.1016/j.addbeh.2017.08.038>
- Chapman, C., & Lahav, M. (2008). International ethnographic observation of social networking sites. In M. Czerwinski & A. Lund (Eds.) *CHI EA '08: CHI '08 Extended Abstracts on Human Factors in Computing Systems* (pp. 3123–3128). ACM. <https://doi.org/10.1145/1358628.1358818>
- Chen, F. F. (2007). Sensitivity of Goodness of Fit Indexes to Lack of Measurement Invariance. *Structural Equation Modeling: A Multidisciplinary Journal*, 14(3), 464–504. <https://doi.org/10.1080/10705510701301834>
- Cheung, G. W., & Rensvold, R. B. (2002). Evaluating Goodness-of-Fit Indexes for Testing Measurement Invariance. *Structural Equation Modeling: A Multidisciplinary Journal*, 9(2), 233–255. https://doi.org/10.1207/S15328007SEM0902_5
- Čolović, P., Mitrović, D., i Smederevac, S. (2005). Evaluacija modela Pet velikih u našoj kulturi primenom upitnika FIBI [Evaluation of Big Five model in Serbian culture by FIBI questionnaire]. *Psihologija*, 38(1), 55–76. <https://doi.org/10.2298/PSI0501055C>
- Correa, T., Hinsley, A. W., & de Zúñiga, H. G. (2010). Who interacts on the Web?: The intersection of users' personality and social media use. *Computers in Human Behavior*, 26(2), 247–253. <https://doi.org/10.1016/j.chb.2009.09.003>
- Dinić, B. M., & Vujić, A. (2019). Five-factor model best describes narcissistic personality inventory across different item response formats. *Psychological Reports*, 122(5), 1946–1966. <https://doi.org/10.1177/0033294118794404>
- Eftekhari, A., Fullwood, C., & Morris, N. (2014). Capturing personality from Facebook photos and photo-related activities: How much exposure do you need?. *Computers in Human Behavior*, 37, 162–170. <https://doi.org/10.1016/j.chb.2014.04.048>
- Ellison, N. B., Steinfield, C., & Lampe, C. (2007). The benefits of facebook “friends:” Social capital and college students' use of online social network sites. *Journal of Computer-mediated Communication*, 12(4), 1143–1168. <https://doi.org/10.1111/j.1083-6101.2007.00367.x>
- Eloranta, J., Kermani, H., & Rahimi, B. (2016). Facebook Iran: Social Capital and the Iranian Social Media. In D. M. Faris & B. Rahimi (Eds.), *Social media in Iran: Politics and society after 2009* (pp. 19–34). SUNY Press.

- Fallahi, Z. & Latifi, N. (2015). The Relationship between Personality Traits, Self-Esteem, and Intensity of Facebook Usage among Tehrani High School Students. *Quarterly Journal of Family and Research*, 12, 85–102.
- Fossati, A., Borroni, S., & Maffei, C. (2013). Psychometric Properties of the Italian Version of the Narcissistic Personality Inventory. *Rivista di Psicologia Clinica*, 1, 96–115.
- Fossati, A., Borroni, S., Marchione, D., & Maffei, C. (2011). The Big Five Inventory (BFI): Reliability and validity of its Italian translation in three independent nonclinical samples. *European Journal of Psychological Assessment*, 27(1), 50–58. <https://doi.org/10.1027/1015-5759/a000043>
- Gerson, J., Plagnol, A. C., & Corr, P. J. (2017). Passive and Active Facebook Use Measure (PAUM): Validation and relationship to the Reinforcement Sensitivity Theory. *Personality and Individual Differences*, 117, 81–90. <https://doi.org/10.1016/j.paid.2017.05.034>
- Granovetter, M. S. (1973). The strength of weak ties. *American Journal of Sociology*, 78(6), 1360–1380. <https://doi.org/10.1086/225469>
- Internet World Stat. (2021, June 10th). *Internet World Stat* <https://www.internetworldstats.com/stats4.htm>
- Ivnik, M. (2014). *Osobine ličnosti, ljubomora i korištenje Facebooka [Personality traits, jealousy and Facebook use]* [Master thesis, Sveučilište u Zadru]. Sveučilište u Zadru <http://www.unizd.hr/Portals/12/Zavrzni%20radovi/2014/Zavrzni%20rad%20-%20Magdalena%20Ivnik.pdf>
- Jakšić, N., Milas, G., Ivezić, E., Wertag, A., Jokić-Begić, N., & Pincus, A. L. (2014). The Pathological Narcissism Inventory (PNI) in transitional post-war Croatia: Psychometric and cultural considerations. *Journal of Psychopathology and Behavioral Assessment*, 36(4), 640–652. <https://doi.org/10.1007/s10862-014-9425-2>
- Janati, A. (2014, January 14). *Iranian Facebook users' statistic by the minister of culture*. Tabnak website: <https://www.tabnak.ir/fa/news/371369/%D8%A2%D9%85%D8%A7%D8%B1-%D8%A7%DB%8C%D8%B1%D8%A7%D9%86%DB%8C%D8%A7%D9%86-%D9%81%DB%8C%D8%B3%E2%80%8C%D8%A8%D9%88%DA%A9%DB%8C-%D8%A7%D8%B2-%D8%B2%D8%A8%D8%A7%D9%86-%D9%88%D8%B2%DB%8C%D8%B1-%D8%A7%D8%B1%D8%B4%D8%A7%D8%AF>
- Johannes, N., Nguyen, T. V., Weinstein, N., & Przybylski, A. K. (2021). Objective, subjective, and accurate reporting of social media use: No evidence that daily social media use correlates with personality traits, motivational states, or well-being. *Technology, Mind, and Behavior*, 2(2). <https://doi.org/10.1037/tmb0000035>
- John, O. P., Donahue, E. M., & Kentle, R. L. (1991). Big five inventory. *Journal of Personality and Social Psychology*. <https://doi.org/10.1037/t07550-000>
- Joinson, A. (2008). Looking at, looking up or keeping up with people?: Motives and use of facebook. In M. Czerwinski & A. Lund (Eds.) *CHI EA '08: CHI '08 Extended Abstracts on Human Factors in Computing Systems* (pp. 1027–1036). ACM. <https://doi.org/10.1145/1357054.1357213>
- Jovanović, T., & Bodroža, B. (2013). Personality traits and Facebook use: Gender differences in online behaviors. In *Current Trends in Psychology* (pp. 153–154). Novi Sad: University of Novi Sad, Faculty of Philosophy. <http://psihologija.ff.uns.ac.rs/repository/puni.php?sifra=stup2013>
- Jovanović, T., Bodroža, B., Buljan, I., Hren, D., Casale, S., Fioravanti, G., Kermani, H., Rivera, K., de los Rios, F., M., Sanjuan, A., M., Orchard, L., Fullwood, C. (2018, May 30th-June 2nd). *Kros-kulturalno istraživanje obrazaca korišćenja Facebook-a kod mladih: Deskriptivna analiza podataka iz sedam zemalja [Cross-cultural research on Facebook use patterns among young people: Descriptive analysis of the data from the seven countries]* [Conference presentation abstract]. 66. Kongres Psihologa Srbije - Futurizam

- u psihologiji, Društvo Psihologa Srbije, Zlatibor, Srbija. http://dps.org.rs/images/66_Naucno-strucni_skup_-_Kongres_psihologa_Srbije_-_Knjiga_rezimea.pdf
- Karl, K., Peluchette, J., & Schlaegel, C. (2010). Who's Posting Facebook Faux Pas? A Cross-Cultural Examination of Personality Differences. *International Journal of Selection and Assessment*, 18(2), 174–186. <https://doi.org/10.1111/j.1468-2389.2010.00499.x>
- Khosraviniq, M., & Zia, M. (2014). Persian Nationalism, Identity and Anti-Arab Sentiments in Iranian Facebook Discourses: Critical Discourse Analysis and Social Media Communication. *Journal of Language and Politics*, 13(4), 755–780. <http://dx.doi.org/10.1075/jlp.13.4.08kho>
- Krasnova, H., Veltri, N., & Günter, O. (2012). Self-disclosure and privacy calculus on social networking sites: the role of culture. *Business & Information Systems Engineering*, 4(3), 127–135. <https://doi.org/10.1007/s12599-012-0216-6>
- Kraut, R., Kiesler, S., Boneva, B., Cummings, J., Helgeson, V., & Crawford, A. (2002). Internet paradox revisited. *Journal of Social Issues*, 58(1), 49–74. <https://doi.org/10.1111/1540-4560.00248>
- Kross, E., Verduyn, P., Demiralp, E., Park, J., Lee, D. S., Lin, N., Shablack, H., Jonides, J. & Ybarra, O. (2013). Facebook Use Predicts Declines in Subjective Well-Being in Young Adults. *PLoS ONE*, 8(8), e69841. <https://doi.org/10.1371/journal.pone.0069841>
- Lampe, C., Ellison, N., & Steinfield, C. (2006). A Face(book) in the crowd: social searching vs. social browsing. In P. Hinds & D. Martin (Eds.) *CSCW '06: Proceedings of the 2006 20th anniversary conference on Computer supported cooperative work* (pp. 167–170). ACM. <https://doi.org/10.1145/1180875.1180901>
- Liu, D., Ainsworth, S. E., & Baumeister, R. F. (2016). A meta-analysis of social networking online and social capital. *Review of General Psychology*, 20(4), 369–391. <https://doi.org/10.1037/gpr0000091>
- Liu, D., & Baumeister, R. F. (2016). Social networking online and personality of self-worth: A meta-analysis. *Journal of Research in Personality*, 64, 79–89. <https://doi.org/10.1016/j.jrp.2016.06.024>
- Mamić, S. (2014). *Odnos narcizma i nekih aspekata korištenja Facebooka. [The relationship between narcissism and certain aspects of Facebook use]* [Master thesis, Sveučilište u Zadru]. Sveučilište u Zadru. <http://www.unizd.hr/Portals/12/Zavrzni%20radovi/2014/Zavr%C5%A1ni%20rad%20-%20Severina%20Mami%C4%87.pdf>
- McCain, J. L., & Campbell, W. K. (2018). Narcissism and social media use: A meta-analytic review. *Psychology of Popular Media Culture*, 7(3), 308–327. <https://doi.org/10.1037/ppm0000137>
- Mehdizadeh, S. (2010). Self-Presentation 2.0: Narcissism and Self-Esteem on Facebook. *Cyberpsychology, Behavior & Social Networking*, 13(4), 357–364. <https://doi.org/10.1089/cyber.2009.0257>
- Michikyan, M., Subrahmanyam, K., & Dennis, J. (2014). Can you tell who I am? Neuroticism, extraversion, and online self-presentation among young adults. *Computers in Human Behavior*, 33, 179–183. <https://doi.org/10.1016/j.chb.2014.01.010>
- Miller, J. D., Price, J., Gentile, B., Lynam, D. R., & Campbell, W. K. (2012). Grandiose and vulnerable narcissism from the perspective of the interpersonal circumplex. *Personality and Individual Differences*, 53(4), 507–512. <https://doi.org/10.1111/j.1467-6494.2010.00711.x>
- Moore, K., & McElroy, J. C. (2012). The influence of personality on Facebook usage, wall postings, and regret. *Computers in Human Behavior*, 28(1), 267–274. <https://doi.org/10.1016/j.chb.2011.09.009>
- Muscianell, N. L., & Guadagno, R. E. (2012). Make new friends or keep the old: Gender and personality differences in social networking use. *Computers in Human Behavior*, 28(1), 107–112. <https://doi.org/10.1016/j.chb.2011.08.016>
- Muthén, B., & Muthén, B. O. (2009). *Statistical analysis with latent variables*. Wiley.

- Ong, E. Y. L., Ang, R. P., Ho, J. C. M., Lim, J. C. Y., Goh, D. H., Lee, C. S., & Chua, A. Y. K. (2011). Narcissism, extraversion and adolescents' self-presentation on Facebook. *Personality and Individual Differences, 50*(2), 180–185. <https://doi.org/10.1016/j.paid.2010.09.022>
- Orchard, L. J., Fullwood, C., Galbraith, N., & Morris, N. (2014). Individual Differences as Predictors of Social Networking. *Journal of Computer-Mediated Communication, 19*(3), 388–402. <https://doi.org/10.1111/jcc4.12068>
- Ross, C., Orr, E. S., Siscic, M., Arseneault, J. M., Simmering, M. G., & Orr, R. R. (2009). Personality and motivations associated with Facebook use. *Computers in Human Behavior, 25*, 578–586. <https://doi.org/10.1016/j.chb.2008.12.024>
- Scharkow, M. (2016). The accuracy of self-reported internet use—A validation study using client log data. *Communication Methods and Measures, 10*(1), 13–27. <https://doi.org/10.1080/19312458.2015.1118446>
- Seidman, G. (2013). Self-presentation and belonging on Facebook: How personality influences social media use and motivations. *Personality and Individual Differences, 54*(3), 402–407. <http://dx.doi.org/10.1016/j.paid.2012.10.009>
- Sigerson, L., & Cheng, C. (2018). Scales for measuring user engagement with social network sites: A systematic review of psychometric properties. *Computers in Human Behavior, 83*, 87–105. <https://doi.org/10.1016/j.chb.2018.01.023>
- Skues, J. L., Williams, B., & Wise, L. (2012). The effects of personality traits, self-esteem, loneliness, and narcissism on Facebook use among university students. *Computers in Human Behavior, 28*(6), 2414–2419. <https://doi.org/10.1016/j.chb.2012.07.012>
- Statista (2021, April). *Top 15 countries based on number of Facebook users*. <https://www.statista.com/statistics/268136/top-15-countries-based-on-number-of-facebook-users/>
- Vasalou, A., Joinson, A. N., & Courvoisier, D. (2010). Cultural differences, experience with social networks and the nature of “true commitment” in Facebook. *International Journal of Human-Computer Studies, 68*(10), 719–728. <https://doi.org/10.1016/j.ijhcs.2010.06.002>
- Wilson, K., Fornasier, S., & White, K. M. (2010). Psychological Predictors of Young Adults' Use of Social Networking Sites. *Cyberpsychology, Behavior, and Social Networking, 13*(2), 173–177. <https://doi.org/10.1089/cyber.2009.0094>

Kros-kulturna validacija skale psiho-socijalnih aspekata korišćenja Fejsbuka (PSAFU)

Tamara Jovanović¹, Bojana Bodroža², Lisa Orchard³, Chris Fullwood³, Hossein Kermani⁴, Silvia Casale⁵, Giulia Fioravanti⁵, Ivan Buljan⁶, & Darko Hren⁷

¹Department za Geografiju, turizam i hotelijerstvo, Fakultet nauka, Univerzitet u Novom Sadu, Srbija

²Department za Psihologiju, Univerzitet u Novom Sadu, Srbija

³Institute of Human Sciences, Faculty of Education Health and Wellbeing, University of Wolverhampton, United Kingdom

⁴Department of Communication, University of Vienna, Austria

⁵Department of Health Sciences, Psychology and Psychiatry Unit, University of Florence, Italy

⁶Department for Research in biomedicine and health, School of Medicine, University of Split, Croatia

⁷Chair of Psychology, Faculty of Humanities and Social Sciences, University of Split, Croatia

Skalu psiho-socijalnih aspekata korišćenja Fejsbuka (PSAFU) su razvili Bodroža i Jovanović (2016) kako bi mogli da adekvatno mere psihološke i socijalne aspekte iskustava korisnika Fejsbuka (FB), tačnije kompenzatorno korišćenje FB, samo-prezentaciju na FB, socijalizaciju i traženje seksualnih partnera na FB, zavisnost od FB i FB profil kao virtuelni self. Skala je prethodno validirana na dva srpska uzorka. Cilj ovog istraživanja jeste validacija PSAFU skale u većem broju kultura, odnosno razvijanje verzije ove skale koja će biti podobna za kros-kulturno ispitivanje ponašanja na FB. Uzorak je činilo 1.632 ispitanika iz Hrvatske, Italije, Irana, Srbije i Ujedinjenog Kraljevstva. Zadati upitnici su bili PSAFU skala (Bodroža & Jovanović, 2016), Inventar Velikih Pet (BFI; John et al., 1991), Inventar Narcisoidne Ličnosti 16 (NPI-16; Ames et al., 2006), socio-demografska pitanja, kao i pitanja o korišćenju FB (npr. vreme provedeno na FB u toku dana, učestalost postavljanja sadržaja i broj FB prijatelja). Posle određenih modifikacija i isključenja skale Virtuelni Self, rezultati višegrupne (eng. multigroup) konfirmatorne faktorske analize pokazuju da PSAFU skala poseduje kros-kulturnu invarijantnost u ispitivanim kulturama i da je pogodna za korišćenje u njima. Preostale dimenzije izmenjene PSAFU skale (PSAFU-R) ostvaruju statistički značajne odnose sa merenim osobinama ličnosti i indikatorima korišćenja FB, iako su dobijene i određene kros-kulturne varijacije.

Ključne reči: PSAFU skala, korišćenje FB, osobine ličnosti, kros-kulturni kontekst

RECEIVED: 02.07.2021.

REVISION RECEIVED: 14.01.2022.

ACCEPTED: 31.01.2022.

© 2023 by authors



This article is an open access article distributed under the terms and conditions of the Creative Commons Attribution ShareAlike 4.0 International license

Appendix A
Descriptive statistics and reliabilities for all continuous variables

Variable	Country	Min	Max	M	SD	Skew.	Kurt.	K-S test (p value)	Cronbach's α
Compensation (PSAFU-R)	Iran	1.00	4.50	2.23	0.82	0.46	-0.48	<.001	.77
	Italy	1.00	4.17	1.46	0.57	1.60	2.74	<.001	.82
	Croatia	1.00	4.67	1.77	0.79	1.11	0.85	<.001	.86
	UK	1.00	4.67	1.97	0.87	0.87	0.12	<.001	.85
	Serbia	1.00	3.83	1.64	0.68	0.98	0.05	<.001	.81
Self-Presentation (PSAFU-R)	Iran	1.00	4.67	2.85	0.84	-0.11	-0.77	<.001	.81
	Italy	1.00	5.00	2.32	0.90	0.45	-0.48	<.001	.86
	Croatia	1.00	5.00	2.51	0.94	0.37	-0.44	.002	.88
	UK	1.00	5.00	2.76	0.99	0.12	-0.61	.046	.85
	Serbia	1.00	5.00	2.33	1.01	0.50	-0.63	<.001	.90
Socialization (PSAFU-R)	Iran	1.00	4.40	2.23	0.83	0.48	-0.51	<.001	.75
	Italy	1.00	5.00	2.22	0.85	0.47	-0.50	<.001	.78
	Croatia	1.00	4.40	1.89	0.77	0.94	0.28	<.001	.76
	UK	1.00	4.60	2.01	0.86	0.82	0.02	<.001	.74
	Serbia	1.00	5.00	2.15	0.92	0.64	-0.48	<.001	.78
Addiction (PSAFU-R)	Iran	1.00	4.25	1.88	0.82	0.81	-0.20	<.001	.71
	Italy	1.00	4.75	1.58	0.65	1.31	1.82	<.001	.67
	Croatia	1.00	4.75	1.97	0.87	0.87	-0.01	<.001	.80
	UK	1.00	4.50	1.98	0.87	0.85	0.00	<.001	.75
	Serbia	1.00	4.75	1.79	0.80	1.19	1.00	<.001	.77
No of FB friends	Iran	100	1000	284.24	232.47	1.82	2.68	<.001	-
	Italy	10	4675	760.38	627.95	2.37	8.56	<.001	-
	Croatia	0	4400	314.50	324.22	8.17	97.74	<.001	-
	UK	4	4000	407.71	444.52	3.79	22.31	<.001	-
	Serbia	5	4896	571.09	474.83	3.79	26.34	<.001	-
BFI Extraversion	Iran	8	40	24.85	5.83	-0.25	-0.11	.062	.78
	Italy	10	40	26.47	5.94	-0.08	-0.22	.004	.83
	Croatia	6	40	27.21	5.87	-0.35	0.12	.020	.83
	UK	9	39	26.27	5.86	-0.11	-0.22	.033	.84
	Serbia	14	40	28.48	5.85	-0.30	-0.55	<.001	.83
BFI Agreeableness	Iran	10	44	32.99	4.66	-0.85	1.88	<.001	.56
	Italy	15	43	31.86	5.22	-0.36	-0.03	<.001	.68
	Croatia	5	45	33.75	5.44	-0.89	2.60	.009	.77
	UK	13	45	34.10	5.19	-0.56	0.96	.012	.72
	Serbia	10	45	35.21	5.38	-0.56	0.77	.001	.76
BFI Conscientiousness	Iran	8	42	28.80	5.09	-0.27	0.47	.004	.58
	Italy	9	45	30.19	6.38	-0.15	-0.23	.031	.83
	Croatia	6	45	31.01	5.68	-0.17	0.74	.002	.80
	UK	18	44	31.34	5.47	0.02	-0.43	.013	.78
	Serbia	15	44	31.69	5.89	-0.16	-0.17	.026	.80

Variable	Country	<i>Min</i>	<i>Max</i>	<i>M</i>	<i>SD</i>	<i>Skew.</i>	<i>Kurt.</i>	<i>K-S test</i> (<i>p</i> value)	Cronbach's α
BFI Neuroticism	Iran	3	40	23.16	5.73	0.01	0.01	.012	.77
	Italy	8	39	25.09	6.13	-0.14	-0.41	.014	.81
	Croatia	4	38	22.98	5.76	-0.01	0.16	<.001	.81
	UK	8	39	24.94	6.23	-0.05	-0.40	.045	.82
	Serbia	8	39	23.15	6.11	0.05	-0.50	.003	.80
BFI Openness	Iran	8	50	36.63	6.22	-0.87	2.50	.003	.80
	Italy	17	50	37.13	6.62	-0.45	0.01	<.001	.81
	Croatia	1	49	35.72	6.71	-0.63	2.02	.031	.84
	UK	14	49	34.38	5.14	-0.15	0.85	.001	.68
	Serbia	13	50	36.70	7.57	-0.45	-0.17	.003	.87
Narcissism	Iran	0	15	5.32	3.30	0.50	-0.31	<.001	.76
	Italy	0	16	3.66	2.94	0.99	0.88	<.001	.74
	Croatia	0	16	4.82	3.39	0.78	0.30	<.001	.77
	UK	0	16	2.86	3.25	1.63	2.70	<.001	.84
	Serbia	0	15	5.40	3.24	0.49	-0.31	<.001	.71

Appendix B
Descriptive statistics for time spent on Facebook on daily basis and frequency of posting

Variable	Answer category	Country									
		Iran		Italy		Croatia		UK		Serbia	
		<i>N</i>	%	<i>N</i>	%	<i>N</i>	%	<i>N</i>	%	<i>N</i>	%
Time spent on FB on daily basis	less than hour	132	42.4	201	46.9	102	38.1	121	48.2	135	36.2
	1–3 hours	131	42.1	203	47.3	133	49.6	101	40.2	157	42.1
	3–5 hours	35	11.3	17	4.0	25	9.3	18	7.2	57	15.3
	more than five hours	12	3.9	6	1.4	8	3.0	5	2.0	24	6.4
	Sum	310	99.7	427	99.5	268	100.0	245	97.6	373	100.0
Frequency of posting	rarely-never	26	8.4	134	31.2	118	44.0	64	25.5	103	27.6
	once in a few weeks	13	4.2	118	27.5	93	34.7	71	28.3	134	35.9
	once a week	20	6.4	60	14.0	26	9.7	33	13.1	50	13.4
	once in 2–3 days	53	17.0	69	16.1	23	8.6	43	17.1	62	16.6
	once a day	198	63.7	23	5.4	5	1.9	22	8.8	12	3.2
	Sum	310	99.7	22	5.1	3	1.1	11	4.4	12	3.2

Note. The difference between 100% and the sum of percentages of answers represents the missing values.

Appendix C

New version of the scale Psycho-Social Aspects of Facebook Use

The list of PSAFU items that were retained in the final model (C-compensation, SP-self-presentation, SOC– socialization, A-addiction). Numbers of the items correspond to the item numbers in the long version of the scale (Bodroža & Jovanović, 2016) and also to the numbers on the Figure 1.

-
- C8. I have more fun socialising on Facebook than socialising offline.
- C10. I find it easier to communicate with people on Facebook than in face-to-face settings.
- C31. On Facebook I feel less pressured to be what others want me to be.
- C32. On Facebook I feel more accepted and appreciated than I do offline.
- C34. I communicate more freely on Facebook than I do offline.
- C35. I find it easier to communicate on Facebook, because I don't have to think about how I look.
-
- SP16. When I post information about myself on Facebook I think about how I would like others to perceive me.
- SP21. I care about the impressions others form about me when they see my profile.
- SP22. I pay a lot of attention to details of my Facebook profile, because I want to make a good impression on those who view it.
- SP24. I try to present myself positively on my Facebook profile especially for those people who do not know me well.
- SP41. I try to make a good impression on others by the things I post on my timeline.
- SP42. Before I post anything on Facebook, I think about how others might perceive it.
-
- SOC12. I have initiated face-to-face contact with a person whom I have got to know through Facebook.
- SOC14. I like to flirt with people on Facebook.
- SOC15. Facebook is a way to meet new and interesting people.
- SOC36. I spend time on Facebook chatting with people who I do not know very well in my offline life.
- SOC37. Sometimes I communicate via phone, sms, skype, etc. with people who I first met on Facebook.
-
- A2. I often put off my other obligations for activities on Facebook (writing messages, browsing, posting links or photos, etc.).
- A3. Some of the people around me have told me that I spend too much time on Facebook.
- A4. I have tried many times to reduce the time I spend on Facebook but have never succeeded.
- A38. Sometimes I lose sleep because I spend long periods of time on Facebook.
-