

## A Single Chip System for Sensor Data Fusion Based on a Drift-diffusion Model

Item Type	Conference contribution
Authors	Yang, Shufan;Wong-Lin, Kongfatt;Rano, Inaki;Lindsay, Anthony
Citation	Intelligent Systems Conference (IntelliSys) 2017, London, UK. IEEE. 4 pp.
DOI	<a href="https://doi.org/10.1109/IntelliSys.2017.8324291">10.1109/IntelliSys.2017.8324291</a>
Publisher	IEEE
Download date	2026-05-17 03:33:05
License	<a href="https://creativecommons.org/licenses/by-nc-nd/4.0/">https://creativecommons.org/licenses/by-nc-nd/4.0/</a>
Link to Item	<a href="http://hdl.handle.net/2436/620403">http://hdl.handle.net/2436/620403</a>

# A Single Chip System for Sensor Data Fusion Based on a Drift-diffusion Model

Dr. Shufan Yang<sup>1</sup>

<sup>1</sup>School of Mathematics and Computer Science,  
Faculty of Science and Engineering, University of  
Wolverhampton, UK  
s.yang@wlv.ac.uk

Dr Kongfatt Wong-Lin<sup>2</sup>, Dr Inaki Rano<sup>2</sup>, and Anthony  
Lindsay<sup>2</sup>

<sup>2</sup>Intelligent Systems Research Centre, School of Computing and  
Intelligent Systems, University of Ulster, UK

## ABSTRACT

*Current multisensory system face data communication overhead in integrating disparate sensor data to build a coherent and accurate global phenomenon. We present here a novel hardware and software co-design platform for a heterogeneous data fusion solution based on a perceptual decision making approach (the Drift-diffusion model). It provides a convenient infrastructure for sensor data acquisition and data integration and only uses a single chip Xilinx ZYNQ-7000 XC7Z020 AP SOC. A case study of controlling the moving speed of a single ground-based robot, according to physiological states of the operator based on heart rates, is conducted and demonstrates the possibility of integrated sensor data fusion architecture. The results of our DDM-based data integration shows a better correlation coefficient with the raw ECG signal compare with a simply piecewise approach.*

**Keywords**—System-on-chip; Data fusion ; ZYNQ

## I. INTRODUCTION

Sensor data fusion is a common and effective foundation for combining the information provided by sensors and building coherent and accurate global phenomena, such as applications in mobile robotic system, signal processing and bioinformatics. Multisensory fusion methods include an actual combination of various sensory resources, while providing the synergistic use of the information provided by various sensory data in the accomplishment of a system task. How to integrate multiple sensor data resources is a challenging problem due to communication overhead and synchronise of various data sources [1].

Conventional multisensory fusion is based on a hierarchical structure, such as control hierarchy [2], logical sensor network [3] and JDL model [4]. Those multisensory integration must first be effectively modelled to represent the uncertainty and error in sensor data. Since the data fusion happens after sensory data has been modelled, the actual data

integrate only happen at different level of data acquisition, which causes the data communication overhead.

In terms of single chip based data integration architecture, there are only a few works in this area. For instance, data integration architecture has been introduced using adaptive Kalman filters and its variations [5]. Their implementation enabled several sensors to be fuzzed by the correlation of the two variables. Two sensor variables were used by a set of fuzzy logic production rules. However, sensor data needs to come from the signal-level and no solution is provided for mismatch scenarios. Milton (2013) demonstrated the hardware implementation of a sensor fusion approach applied to both an ultrasonic and an infrared sensor to estimate the distance [6]. A Spartan3E FPGA device had been used for distance measurements using both infrared sensors and ultrasound sensors. A central limit theorem (CLT) was used in their system, but the CLT scheme states the distribution of the sum (or average) of a large independent sample was identically normal distributed variables regardless of the underlying distribution. This assumption of CLT has high possibility to over-correct the original sensor data, which introduced calculation errors [7].

Current sensor data fusion systems have been developed with individual products causing long processing overhead due to communication among individual modules. Also, they have problems of integrating multiple sensors with balanced resources between sensor data acquisition and communication capabilities. A solution to these problems is to use a single-chip approach to integrate stimuli at a given timed interval. In this work, we proposed a perceptual decision making based data fusion system on a single system-on-chip device and created a unifying system that can cross application-specific boundaries on a single chip level to meet realistic applications' requirement.

## II. METHOD AND MATERIALS

### A. Drift Diffusion Model

We selected a perception decision making model in this work since it is sufficiently simple and analytically tractable with a small computing power required. One of a well-defined optimum procedure of perception decision making models is drift-diffusion model (DDM) [8] [9]. The mathematical equation governing the process is as the same as a biased Brownian motion:

$$dX = Adt + cdW, X(0) = 0 \quad (1)$$

Where  $dt$  is the time-step over when we integrate the peak of Electrocardiogram (ECG) signal and  $W(t)$  is a random variable that follows a standard Gaussian distribution. The factor  $c$  determines the noise level.  $X(t)$  is the evolving logarithmic likelihood ECG reading and  $A$  is a accumulated threshold that indicates the stress level of operator. Since the sensor data (ECG) constitutes a noise (due to the loss contact of wearable heart beat monitor), the integrated data after DDM model is stochastic rather than deterministic.

### B. Design Platform

Our system uses a Nintendo Wii Nunchuk and a Polar ECG monitor as sensor inputs, connected to the Xilinx ZYNQ 702c board, which performs the data fusion logic. The sensory information is used to drive a WowWeeRovio mobile robot (see Fig 1 for the individual modules of the system). The Polar T31 is a chest-strap personal wireless ECG monitor (Fig 1(F)). The device electrodes connect to the operator's chest and are able to detect the operator's ECG.

In order to receive and process the transmissions from the Polar heart rate monitor, a SparkFun HRM interface acted as a communications bridge by integrating the Polar RMCM-01 heart rate receiver, which are used to interpret the communications from the wireless monitor and transmit the results over a serial bus in Xilinx ZYNQ 702C board.

The flow of integration of data fusion is shown in Fig 2. After data acquisition happens at I2C bus and serial bus which is connected with the Joystick to Zc702 board, the petalinux that runs in ARM cortex A9 schedule the data from I2C integration. An interrupt routine gets the integrated into FPGA data buffer for reading stress mode of operator. If the operator is in stress, the moving speed of mobile robots will reduce each time step until stress levels come down into relax mode.

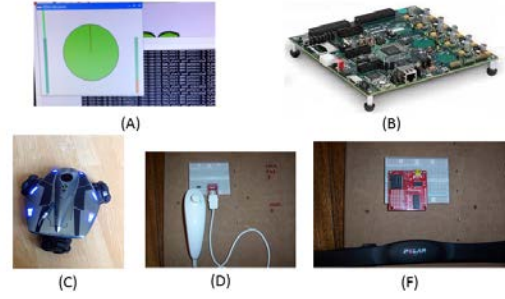

Fig 1. The prototype system. (A) GUI which includes the of the joy stick controlling the ROVIO movement direction (green circle), the observed of heart rate (left bar), and the confidence level of data fusion (right bar). (B) Zynq 702c board used for processing fused data (C) ROVIO wheeled robot. (D) Joy stick. (F) Polar T31 chest-strap ECG monitor and SparkFun Polar HRM interface.

The system-on-chip data fusion flow chart is prototyped on a Xilinx ZYNQ-7000 XC7Z020 SoC, as shown in Fig. 2.

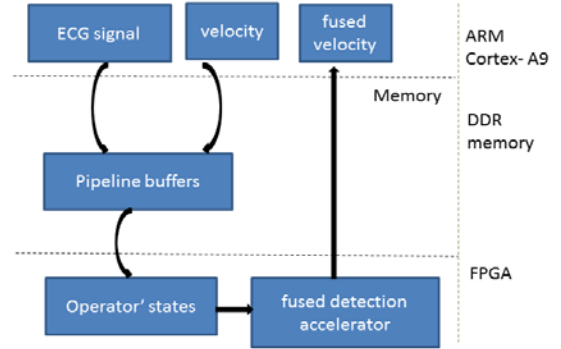

Fig. 2 the flow chat of integrated sensor data fusion platform.

As shown in Fig. 2, it includes a fully-functional ARM-based system and customizable multi-accessible data flows. The SOC resource (shown in red colour in Fig 3) includes all the peripherals that are typically required by data fusion, including DDR memory, GPIOs, Ethernet, I<sup>2</sup>C interrupt controller and memory register banks to exchange states and transfer data with FPGA processing logic. Considering that data is exchanged with FPGA logic through DDR memory, ARM runs a standard Linux-based operation system, which provides Ethernet protocol stacks to communicate though a wireless route.

Although this flow is proposed using Xilinx's SoC platform, the concept is similar for any reconfigurable system-on-chip architectures. It allows developers to quickly validate and prototype image applications in an environment very close to the final implementation on a conventional reconfigurable SoCs architecture.

### C. General Architecture of System-on-chip Data Fusion

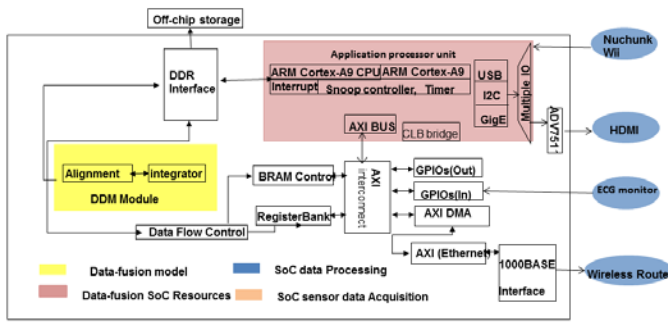

Fig. 3. System-on-chip block diagram.

Fig.3 shows the data fusion processing implemented in the SOC platform. This consists of six stages of operation. The first stage prepares the heart rate reading for the subsequent processing by reading samples. The second stage moves the Nunchuk Wii control velocity in the data alignment by comparing the time of heart rate reading acquired. The third stage implements the fusion module to integrate the heart rate's reading and the velocity providing from Nunchuk Wii. In our implementation, updating the computed speed for moving mobile robots takes 4 clock cycles including updating the variance in the DDR memory. As in the fourth stage, the DDM algorithm is used to calculate statistics of the operator's performance and tolerate random noise from heart beat readings. Our data fusion is both statistically and independently computed with a pipelined fashion. In the fifth stage, the coefficient of velocity in mobile robots is stored in BRAM and is writable by the ARM processor to be able to generate fused control speed for mobile robots. At the sixth stage operation system computes the data processing implemented on FPGA logic; a watchdog timer and a recovery mechanism executed on the ARM processor is used to reboot the ARM processor in the event of an error.

#### D. Wireless Connection

In this work we used wireless connection to connect with the mobile robot Rovio and a ZYNQ board to conduct a simple network utilising the Wireshark and Fiddler software packages [11]. After observing the package, we noticed that, due to the communication to and from the Rovio being held over HTTP, the communication was handled over connection-orientated TCP. Whilst considered reliable, we use formal defined methods to establish, maintain and teardown such communications (IETF, 1981). This form of communication added significant overhead to the communication, with over 50% of the inter-host communication being dedicated to providing these control mechanisms.

Implementing communication over TCP is inefficient, considering overall bandwidth utilisation in comparison to UDP protocol. We implemented the communication control mechanisms within TCP to provide reliable communications, regulated at the transport layer through the TCP state machine, rather than allowing the application processes to handle the communication. This was demonstrated in the Wireshark analysis, where each request from the client to the Rovio, on a single established TCP connection, required an acknowledgement being passed back to the client before further requests could be transmitted.

In single chip platform, the Gigabit Ethernet Media Access Control (MAC) to a wireless router is implemented through the multiplexed I/O interface with Xilinx physical programmable logic IP. In this design we used the 1000BASE-X interface. The transceiver reference clock is 125MHz on the ZC702 board. The Linux driver runs in an ARM processor with abilities of providing Ethernet MAC accesses, AXI DMA transfers and physical media intialisation for the 1000Base interface.

### III. RESULTS

#### A. Implementation

Table I lists the amount and type of resources required by the system-on-chip data fusion platform when implemented on a Zynq XC7Z020 device. The power consumption estimated by Xilinx Vivado tools is approximately 0.74 W, which is considered to be energy efficient.

Table 2 IMPLEMENT RESULTS ON A XILINX ZYNQ XC7Z020

Modules	LUTs	Flip-Flop	DSP48s	BRAMs
Data Acquisition	678	578	-	-
DDM	778	4,535	28	125
Data Processing	7,879	6,155	16	148
Others	20,457	25,972	-	-
TOTAL	53,200	106,400	220	420
	56%	35%	20%	65%

#### B. Performance

For understanding the relationship between human's stress levels with heart rates, an adult human heart rate has been observed in a number of different scenarios. From our tests, it become apparent that the operator has the greatest impact on change of heart rate when the operator is exposed either to a "shock" or a sustained period of physical or emotional exertion, while the other events provide slight increases in

human heart rates. For instance, listening to music provides a very little increase of heart rate. For testing the operator's condition, we collected the heart rate data of a 21 year-old male who was participating to a moderate exercise over 1000 seconds, followed by a stationary recovery period.

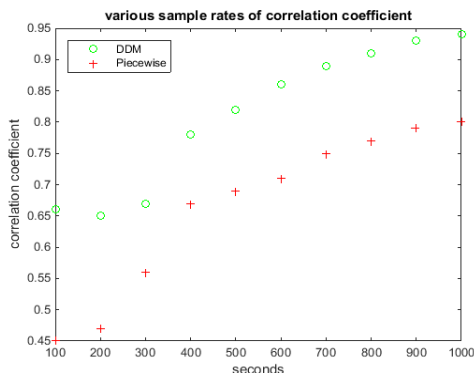

Fig 4. The correlation coefficient comparison between raw ECG signal and with low-pass band filter.

During that period, this participator used a Nintendo Wii Nunchuk to control a moving robot (Wowiee Rovio). For comparison, we processed the ECG signal with a low-pass band filter with piecewise fusion model (if BMP > 60, operation is in a stress mode, if BMP <60, operator is in a relax mode). The result with piecewise fusion model and DDM fusion model with raw ECG signal showed in Fig 4. As illustrated in Fig 4., the DDM model has better statistical matching compare to piecewise fusion method.

#### IV CONCLUSION

Data integration architecture has been introduced and implemented at modular-levels [10]. In many cases process delay and communication overhead cannot be ignored [11, 12]. Therefore, a reliable procedure and low communication overhead system is needed to form an overall integrated system correctly.

Our data fusion framework can incorporate an individual operator's physiological state of reaction to external stimuli to cope with different situations. In future, an adaptive threshold method will be considered to dynamically adjust the threshold for each individual person and optimising the threshold through storing and recalling biometric data of an individual's previously recorded data, hence, personalising the usability of the system and give a global phenomenon for surrounding environment.

#### ACKNOWLEDGMENT

The work was supported by ASUR (1014-C4-Ph1-071).

#### REFERENCES

- [1] Klein, Lawrence A. Sensor and data fusion: a tool for information assessment and decision making. Vol. 324. Bellingham WA: Spie Press, 2004.
- [2] Hall, David, and James Llinas, eds. *Multisensor data fusion*. CRC press, 2001.
- [3] Luo, Ren C., Chih-Chen Yih, and Kuo Lan Su. "Multisensor fusion and integration: approaches, applications, and future research directions." *IEEE Sensors journal* 2.2 (2002): 107-119.
- [4] Llinas, James, et al. *Revisiting the JDL data fusion model II*. SPACE AND NAVAL WARFARE SYSTEMS COMMAND SAN DIEGO CA, 2004.
- [5] Hackett, Jay K., and Mubarak Shah. "Multi-sensor fusion: a perspective." *Robotics and Automation, 1990. Proceedings., 1990 IEEE International Conference on*. IEEE, 1990.
- [6] Conde, Milton E., Sergio Cruz, Daniel M. Munoz, Carlos H. Llanos, and Eugenio LF Fortaleza. "An efficient data fusion architecture for infrared and ultrasonic sensors, using FPGA." In *Circuits and Systems (LASCAS), 2013 IEEE Fourth Latin American Symposium on*, pp. 1-4. IEEE, 2013.
- [7] Malik, Jamshaid Sarwar, et al. "Generating high tail accuracy Gaussian random numbers in hardware using central limit theorem." *2011 IEEE/IFIP 19th International Conference on VLSI and System-on-Chip*. IEEE, 2011.
- [8] Ratcliff, Roger. "A theory of memory retrieval." *Psychological review* 85, no. 2 (1978): 59.
- [9] Broderick, Tamara, Kong Fatt Wong-Lin, and Philip Holmes. "Closed-form approximations of first-passage distributions for a stochastic decision-making model." *Applied Mathematics Research eXpress* 2009.2 (2009): 123-141.
- [10] Hall, D. L., & Llinas, J. (1997). An introduction to multisensor data fusion. *Proceedings of the IEEE*, 85(1), 6-23.
- [11] Al-Dhaher, A. H. G., E. A. Farsi, and D. Mackesy. "Data Fusion Architecture-An FPGA Implementation." In *Instrumentation and Measurement Technology Conference, 2005. IMTC 2005. Proceedings of the IEEE*, vol. 3, pp. 1985-1990. IEEE, 2005.
- [12] Salina, B., and P. Malathi. "FPGA implementation of data fusion algorithm for object localization." In *Recent Advances and Innovations in Engineering (ICRAIE), 2014*, pp. 1-5. IEEE, 2014.

